

# Operation & Maintenance Manual



## Spray Booth General Maintenance & Operation

# Spray Booth General Maintenance and Specifications

To keep the AMS Spray Booth in good operating condition please make sure the filter is changed on a regular basis, keeping free of particulate allowing regular air flow.

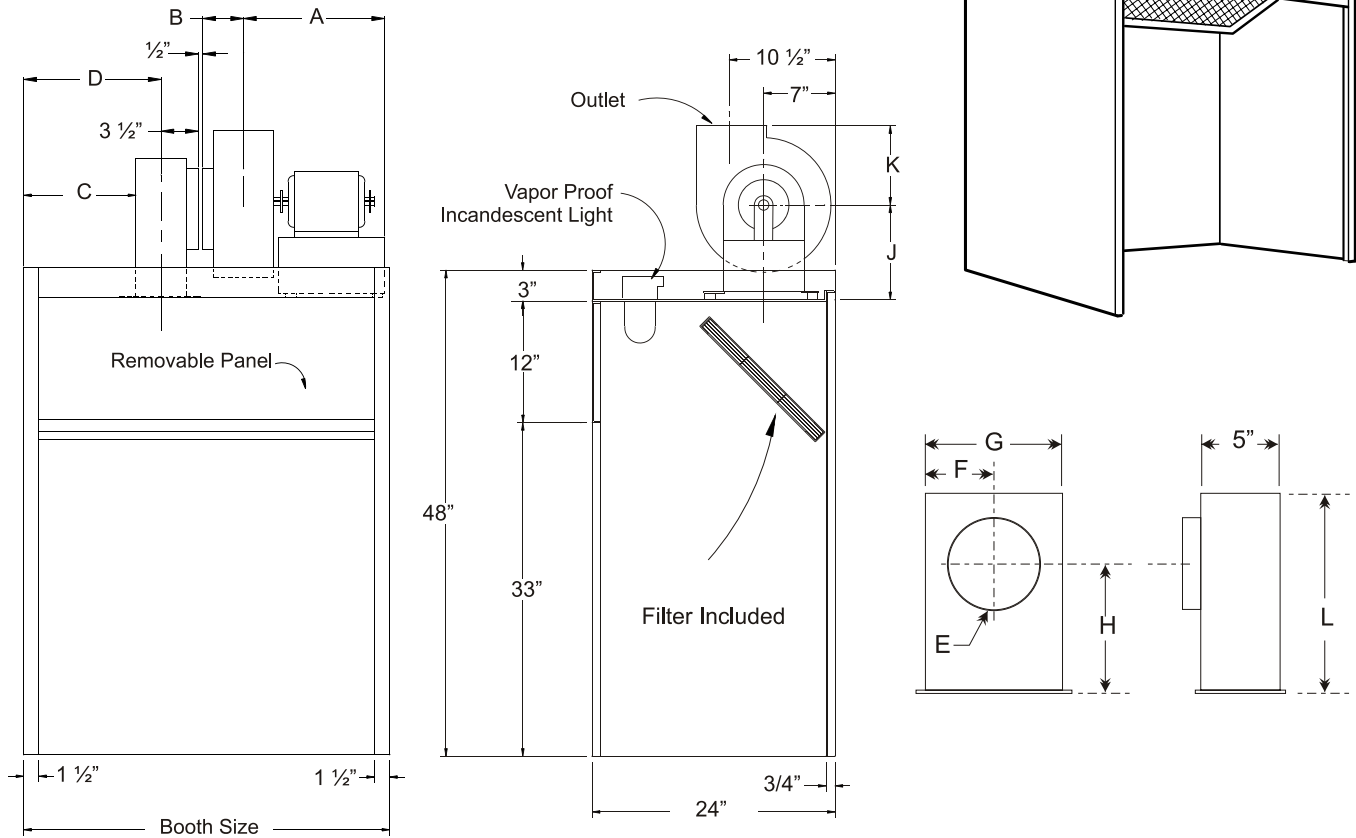

Model	A	B	C	D	E	F	G	H	J	K	L
AMS24SB	10.125"	3.125"	2.250"	4.750"	6"	4"	8"	8.500"	8.250"	5"	8.500"
AMS30SB	10.750"	3.750"	7.250"	9.750"	8"	5"	10"	8.500"	8.250"	6.875"	8.500"
AMS36SB	11.375"	4.375"	11.250"	13.750"	9"	5.500"	11"	9.375"	9.125"	7.125"	9.375"
AMS48SB	11.375"	4.375"	11.250"	19.750"	9"	5.500"	11"	9.375"	9.125"	7.125"	9.375"

Model	Blower	Outlet Size	Filter Size
AMS24SB	#7C037	4.250" x 7.375"	20" x 20" x 1"
AMS30SB	#7C038	5.375" x 8.250"	20" x 20" x 1"
AMS36SB	#7C039	6.500" x 10.750"	(2) 16" x 20" x 1"
AMS48SB	#7C047	8.000" x 13.750"	(2) 20" x 20" x 1"

# PEERLESS BLOWERS DIRECT DRIVE BLOWERS

## PEERLESS BLOWERS DIRECT DRIVE BLOWERS

### APPLICATION:

Used extensively for general ventilation of small areas where duct systems are required. Used for washrooms, restaurants and small hood exhaust. Slow speed units are extremely quiet where noise is a factor.

### FEATURES:

#### General Construction

Housings and bases are 16 gauge steel. Wheels are dynamically balanced and equipped with cast iron hubs. Blowers are finished with baked powered polyester.

#### Motors

Commercial standard Fan and Blower duty motors are job-matched to each requirement. All types of current characteristics, enclosures and bearing construction are available.

#### Rotation and Discharge

Standard units are built for clockwise rotation and bottom horizontal discharge. However, any rotation or discharge will be furnished when so specified. Housings may be easily rotated to any of eight different discharge directions if desired at time of installation.

#### Custom Features

Weather-proof drive covers to cover the motor are available if unit is mounted outside. Also such extras as non-ferrous wheel, vibration pads, discharge dampers, acid resisting paint, inlet or outlet screens and other special features are available for special requirements.

#### Capacities

These blowers are tested in accordance with test codes adopted by AMCA and the American Society of Heating, Refrigerating and Air Conditioning Engineers.



### Direct Drive Blower Performance Data

MODEL NO.	MOTOR HP	BLOWER RPM	FREE AIR		1/8"		1/4"		3/8"		1/2"		5/8"		3/4"		1"		1 1/4"	
			CFM	OV	CFM	OV	CFM	OV	CFM	OV	CFM	OV	CFM	OV	CFM	OV	CFM	OV	CFM	OV
D5A	1/6	1750	184	1630	169	1500	144	1275	112	995	—	—	—	—	—	—	—	—	—	—
D6AA	1/6	1150	390	1880	330	1590	250	1205	100	480	—	—	—	—	—	—	—	—	—	—
D6AB	1/6	1750	595	2865	560	2700	515	2480	470	2265	420	2025	365	1760	300	1445	—	—	—	—
D8A	1/6	1150	760	2570	680	2300	620	2095	535	1810	430	1455	—	—	—	—	—	—	—	—
D8C	1/2	1750	1150	3885	1085	3665	1050	3550	1005	3400	960	3240	915	3090	865	2920	750	2535	580	1960
D9A	1/6	850	875	1870	835	1785	780	1665	680	1450	470	1005	—	—	—	—	—	—	—	—
D9C	1/3	1150	1180	2520	1160	2480	1125	2400	1090	2325	1035	2210	963	2060	855	1825	—	—	—	—
D11D	1/2	850	1520	2395	1380	2170	1290	2025	1145	1800	1010	1585	860	1350	—	—	—	—	—	—
D11E	3/4	1150	2060	3240	1970	3095	1870	2940	1800	2830	1710	2690	1605	2525	1500	2355	1290	2030	1020	1605
D12E	3/4	850	2475	2885	2365	2760	2260	2640	2140	2495	2015	2350	1885	2200	1725	2010	1245	1450	—	—
D12H	2	1150	3350	3900	3275	3815	3195	3725	3115	3630	3025	3530	2940	3430	2850	3320	2660	3100	2450	2855

# PEERLESS BLOWERS DIRECT DRIVE BLOWERS

## PEERLESS BLOWERS HIGH SPEED BLOWERS

### APPLICATION:

Use for systems that require air delivery at high static pressures, such as garage mon-oxide systems, electronic cooling or industrial applications. For lower static pressure use standard blowers as listed on opposite page.

### FEATURES:

#### General Construction

Housings and bases are 16 gauge steel. Wheels are dynamically balanced and equipped with cast iron hubs. Blowers are finished with baked powered polyester.

#### Motors

Commercial standard Fan and Blower duty motors are job-matched to each requirement. All types of current characteristics, enclosures and bearing construction are available.

### Rotation and Discharge

Standard units are built for clockwise rotation and bottom horizontal discharge. However, any rotation or discharge will be furnished when so specified. Housings may be easily rotated to any of eight different discharge directions if desired at time of installation.

### Custom Features

Weather-proof drive covers to cover the motor are available if unit is mounted outside. Also such extras as non-ferrous wheel, vibration pads, discharge dampers, acid resisting paint, inlet or outlet screens and other special features are available for special requirements.

### Capacities

These blowers are tested in accordance with test codes adopted by AMCA and the American Society of Heating, Refrigerating and Air Conditioning Engineers.

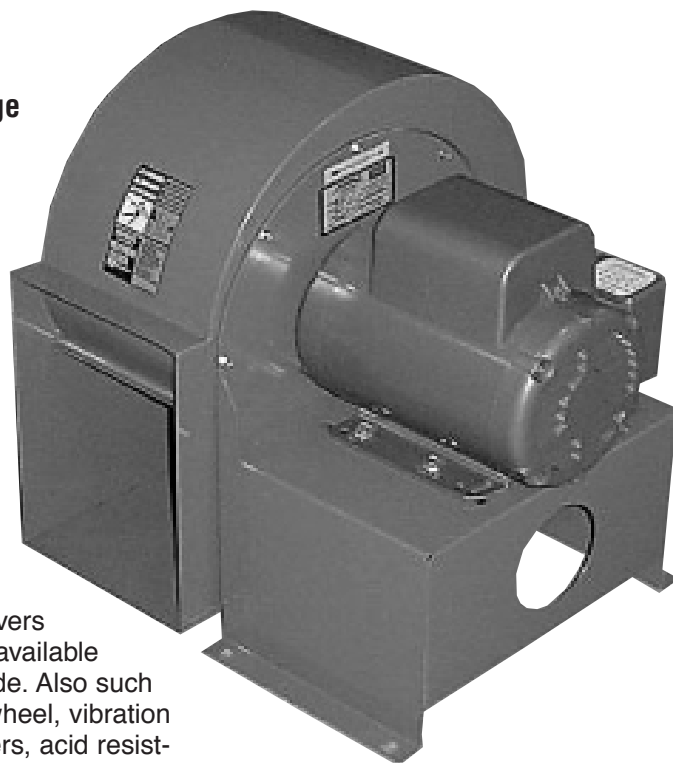

## High Speed Blower Performance Data

MODEL NO.	MOTOR HP	BLOWER RPM	1/2"		3/4"		1"		1 1/4"		1 1/2"		1 3/4"		2"		2 1/4"		2 1/2"		2 3/4"		
			CFM	OV	CFM	OV	CFM	OV	CFM	OV	CFM	OV	CFM	OV	CFM	OV	CFM	OV	CFM	OV	CFM	OV	
D9D	1/2	1750	WILL OVERLOAD MOTOR				895	1910	810	1730	735	1570	615	1315	—	—	—	—	—	—	—	—	—
D9E	3/4	1750	WILL OVERLOAD MOTOR						1550	3310	1445	3085	1290	2755	1100	2345	—	—	—	—	—	—	—
D9F	1	1750	1720	3670	1675	3580	1620	3460	1550	3310	1445	3085	1290	2755	1100	2345	—	—	—	—	—	—	—
D11F	1	1750	WILL OVERLOAD MOTOR									1425	3070	1280	2760	1120	2415	910	1960	—	—	—	—
D11G	1 1/2	1750	WILL OVERLOAD MOTOR								1840	3970	1730	3730	1600	3455	1450	3130	1280	2760	1040	2240	—
D11H	2	1750	WILL OVERLOAD MOTOR							2415	3795	2240	3520	2130	2910	1660	2610	3345	1990	3130	1850	—	—

# PEERLESS BLOWERS DIRECT DRIVE BLOWERS

## Direct Drive Blowers — Arrangement #4

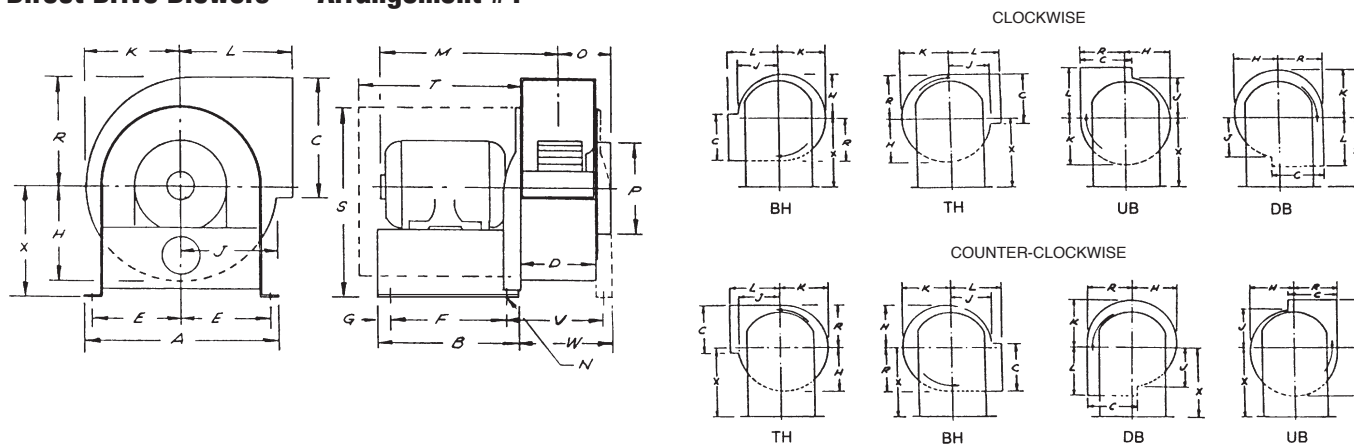

## Direct Drive Blower Dimensions

MODEL	WHEEL	A	B	C	D	E	F	G	H	J	K	L	M*	N	O	P	R	S	T	V	W	X	MAX. MOTOR FRAME
D5A	4 1/2 x 2 1/2	8 3/8	7	5 1/8	3 3/8	3 3/4	6	1/2	3 1/2	3 1/8	3 3/4	4 1/8	11 1/2	3/8	2 3/4	4	4 5/8	8 5/8	9 1/2	—	—	5 1/4	48
D5A	4 3/4 x 2 1/4	8 3/8	7	5 1/8	3 3/8	3 3/4	6	1/2	3 1/2	3 1/8	3 3/4	4 1/8	11 1/4	3/8	2 3/4	4	4 5/8	9 1/8	9 1/2	—	—	5 3/4	56
D6AA D6AB	6 1/4 x 3	9 3/8	8	7 3/8	4 1/4	4 1/4	7	1/2	5	4	6	5	11 7/8	3/8	3 1/8	6	7 1/8	12 3/8	12	—	—	8 1/2	48
D6AA D6AB	6 1/4 x 3	9 3/8	8	7 3/8	4 1/4	4 1/4	7	1/2	5	4	6	5	11 5/8	3/8	3 1/8	6	7 1/8	12 7/8	12	—	—	9	56
D8A D8C	7 3/4 x 3 7/8	11	8	8 1/4	5 3/8	5	7	1/2	6	4 5/8	6 3/4	6 7/8	12 1/2	3/8	3 3/4	8	8	13 1/8	12	—	—	8 1/2	48
D8A D8C	7 3/4 x 3 7/8	11	8	8 1/4	5 3/8	5	7	1/2	6	4 5/8	6 3/4	6 7/8	12 1/4	3/8	3 3/4	8	8	13 5/8	12	—	—	9	56
D9A D9C	9 x 4 1/2	12 1/8	8	10 3/4	6 1/2	5 5/8	7	1/2	6 3/4	5 5/8	7 3/4	7 1/8	13 1/4	3/8	4 3/8	9	9 1/4	14 1/2	16	—	—	9 3/8	48
D9A D9C	9 x 4 1/2	12 1/8	8	10 3/4	6 1/2	5 5/8	7	1/2	6 3/4	5 5/8	7 3/4	7 1/8	13	3/8	4 3/8	9	9 1/4	15	16	—	—	9 7/8	56
D11D D11E	10 5/8 x 5 1/4	14 3/4	9	11 3/4	8	6 7/8	7 1/2	3/4	8	6 3/4	9 1/8	8 1/8	13 7/8	3/8	5	10	10 3/4	18 1/4	16	—	—	11 3/4	56/145T
D11D D11E	10 5/8 x 5 1/4	14 3/4	11 1/2	11 3/4	8	6 7/8	10	3/4	8	6 3/4	9 1/8	8 1/8	15 1/2	3/8	5	10	10 3/4	17 3/4	16	—	—	11 1/4	182T/184T
D12D D12E D12H	12 1/2 x 6 1/2	16 3/8	13	13 1/4	9 5/8	7 3/8	9 3/4	2 1/2	10 1/8	8 1/2	11 1/2	10 1/2	16 3/8	9/16	6 1/2	13 1/4	13 1/4	24 1/4	20	11 1/4	11 1/4	17	182T/184T
D12D D12E D12H	12 1/2 x 6 1/2	16 3/8	13	13 1/4	9 5/8	7 3/8	9 3/4	2 1/2	10 1/8	8 1/2	11 1/2	10 1/2	20 3/4	9/16	6 1/2	13 1/4	13 1/4	24 1/4	20	11 1/4	11 1/4	17	213T/215T

\*"M" dimension will vary on type of motor used.

## High Speed Blower Dimensions

MODEL	HP	RPM	WHEEL	A	B	C	D	E	F	G	H	J	K	L	M*	N	O	P	R	X	MAX. MOTOR FRAME
D9D	1/2	1750	9 x 3	12 1/8	8	10 3/4	6 1/2	5 5/8	7	1/2	6 3/4	5 5/8	7 3/4	7 1/8	13	3/8	4 3/8	9	9 1/4	9 7/8	56
D9E	3/4	1750	9 x 4 1/2	12 1/8	8	10 3/4	6 1/2	5 5/8	17	1/2	6 3/4	5 5/8	7 3/4	7 1/8	13	3/8	4 3/8	9	9 1/4	9 7/8	56
D9F	1	1750	9 x 4 1/2	12 1/8	8	10 3/4	6 1/2	5 5/8	7	1/2	6 3/4	5 5/8	7 3/4	7 1/8	14 1/4	3/8	4 3/8	9	9 1/4	9 7/8	56/145T
D9F	1	1750	9 x 4 1/2	12 1/8	11	10 3/4	6 1/2	5 5/8	10	1/2	6 3/4	5 5/8	7 3/4	7 1/8	15	3/8	4 3/8	9	9 1/4	10 7/8	182T/184T
D11F	1	1750	10 5/8 x 3	14 3/4	9	11 3/4	5 7/8	6 7/8	7 1/2	3/4	8	6 3/4	9 1/8	8 1/8	12 3/4	3/8	4	10	10 3/4	11 1/4	56/145T
D11F	1	1750	10 5/8 x 3	14 3/4	11 1/2	11 3/4	5 7/8	6 7/8	10	3/4	8	6 3/4	9 1/8	8 1/8	14 5/8	3/8	4	10	10 3/4	11 3/4	182T/184T
D11G	1 1/2	1750	10 5/8 x 4	14 3/4	9	11 3/4	5 7/8	6 7/8	7 1/2	3/4	8	6 3/4	9 1/8	8 1/8	12 3/4	3/8	4	10	10 3/4	11 3/4	56/145T
D11G	1 1/2	1750	10 5/8 x 4	14 3/4	11 1/2	11 3/4	5 7/8	6 7/8	10	3/4	8	6 3/4	9 1/8	8 1/8	14 5/8	3/8	4	10	10 3/4	11 1/4	182T/184T
D11H	2	1750	10 5/8 x 5 1/4	14 3/4	9	11 3/4	8	6 7/8	7 1/2	3/4	8	6 3/4	9 1/8	8 1/8	13 7/8	3/8	5	10	10 3/4	11 3/4	56/145T
D11H	2	1750	10 5/8 x 5 1/4	14 3/4	11 1/2	11 3/4	8	6 7/8	10	3/4	8	6 3/4	9 1/8	8 1/8	15 1/2	3/8	5	10	10 3/4	11 1/4	182T/184T

\*"M" dimension will vary on type of motor used.

# Couplings

Cl. I, Groups A, B, C, D  
Cl. II, Groups E, F, G  
Cl. III

Explosionproof  
Dust-Ignitionproof  
Wet Locations

5F

**1/2"-2" Brass Construction**  
**2-1/2-4" Stainless Steel construction only**

## Applications:

EC couplings are used:

- In hazardous areas where a flexible member is required in a conduit system to accomplish difficult bends, or to allow for movement or vibration of connected equipment or units

## Features:

- Rugged design to withstand explosive pressure (Class I)
- Mechanical abuse
- Liquid-tight for wet locations
- For use where lack of space makes use of rigid conduit difficult
- Wire duct liner in sizes 1/2" to 2" insulates against grounds and burn-through from short circuit
- No bonding jumpers required, metallic braid provides continuous electrical path
- ECGJH combination has two threaded male end fittings
- ECLK combination has one female union and one male threaded end fitting

## Certifications and Compliances:

- NEC:
  - 1/2" and 3/4" (Brass and S516) – Class I, Division 1, Groups A, B, C, D
  - 1" to 2" (Brass and S516) – Class I, Division 1, Groups C, D

All sizes also for use in Class II, Division 1, Groups E, F, G and Class III

- UL Standard: 1203
- ATEX and IECEx - **ECGJH S516 Only:**
  - 1/2" and 3/4" (4" to 36" flexible length only) – Ex d IIC, IP66
  - 1", 1 1/4", 1 1/2", 2" (4" to 36" flexible length only) – Ex d IIB, IP66

## Standard Materials and Finishes:

- End fittings:
  - 1/2" to 2" – forged brass; natural
  - 2 1/2" to 4" – stainless steel; natural
- Female unions:
  - 1/2" to 1" – steel; electrogalvanized with chromate treatment
  - 1 1/4" to 4" – *Feraloy*® iron alloy; electrogalvanized with aluminum acrylic paint
- 1/2" to 2" have bronze braid covering and flexible brass inner core; packing is woven cotton braid impregnated with asphalt
- 2 1/2" to 4" have a Type 304 stainless steel braid

## Options:

### Description

All stainless steel (available for ECGJH only)

For severely corrosive locations, a flexible PVC protective coating will be supplied

Special coupling lengths available up to 144 inches. To order, change last two digits in any standard catalog number to the two or three digit length desired in whole inches i.e. To order a 3/4" trade size 110 inches long, use catalog number ECGJH2110.



**ECGJH (Male connections both ends)**

Flexible Length (In.)	Size	Cat. #	Flexible Length (In.)	Size	Cat. #	Flexible Length (In.)	Size	Cat. #
4	1/2	ECGJH14	18	1	ECGJH318	27	2 1/2	ECGJH727
4	3/4	ECGJH24	18	1 1/4	ECGJH418	27	3	ECGJH827
6	1/2	ECGJH16	18	1 1/2	ECGJH518	27	4	ECGJH1027
6	3/4	ECGJH26	18	2	ECGJH618	30	1/2	ECGJH130
6	1	ECGJH36	18	2 1/2	ECGJH718	30	3/4	ECGJH230
8	1/2	ECGJH18	18	3	ECGJH818	30	1	ECGJH330
8	3/4	ECGJH28	18	4	ECGJH1018	30	1 1/4	ECGJH430
8	1	ECGJH38	21	1/2	ECGJH121	30	1 1/2	ECGJH530
10	1/2	ECGJH110	21	3/4	ECGJH221	30	2	ECGJH630
10	3/4	ECGJH210	21	1	ECGJH321	30	2 1/2	ECGJH730
10	1	ECGJH310	21	1 1/4	ECGJH421	30	3	ECGJH830
12	1/2	ECGJH112	21	1 1/2	ECGJH521	30	4	ECGJH1030
12	3/4	ECGJH212	21	2	ECGJH621	33	1/2	ECGJH133
12	1	ECGJH312	21	2 1/2	ECGJH721	33	3/4	ECGJH233
12	1 1/4	ECGJH412	21	3	ECGJH821	33	1	ECGJH333
12	1 1/2	ECGJH512	21	4	ECGJH1021	33	1 1/4	ECGJH433
12	2	ECGJH612	24	1/2	ECGJH124	33	1 1/2	ECGJH533
12	2 1/2	ECGJH712	24	3/4	ECGJH224	33	2	ECGJH633
12	3	ECGJH812	24	1	ECGJH324	33	2 1/2	ECGJH733
12	4	ECGJH1012	24	1 1/4	ECGJH424	33	3	ECGJH833
15	1/2	ECGJH115	24	1 1/2	ECGJH524	33	4	ECGJH1033
15	3/4	ECGJH215	24	2	ECGJH624	36	1/2	ECGJH136
15	1	ECGJH315	24	2 1/2	ECGJH724	36	3/4	ECGJH236
15	1 1/4	ECGJH415	24	3	ECGJH824	36	1	ECGJH336
15	1 1/2	ECGJH515	24	4	ECGJH1024	36	1 1/4	ECGJH436
15	2	ECGJH615	27	1/2	ECGJH127	36	1 1/2	ECGJH536
15	2 1/2	ECGJH715	27	3/4	ECGJH227	36	2	ECGJH636
15	3	ECGJH815	27	1	ECGJH327	36	2 1/2	ECGJH736
15	4	ECGJH1015	27	1 1/4	ECGJH427	36	3	ECGJH836
18	1/2	ECGJH118	27	1 1/2	ECGJH527	36	4	ECGJH1036
18	3/4	ECGJH218	27	2	ECGJH627			

## Dimensions In Inches:

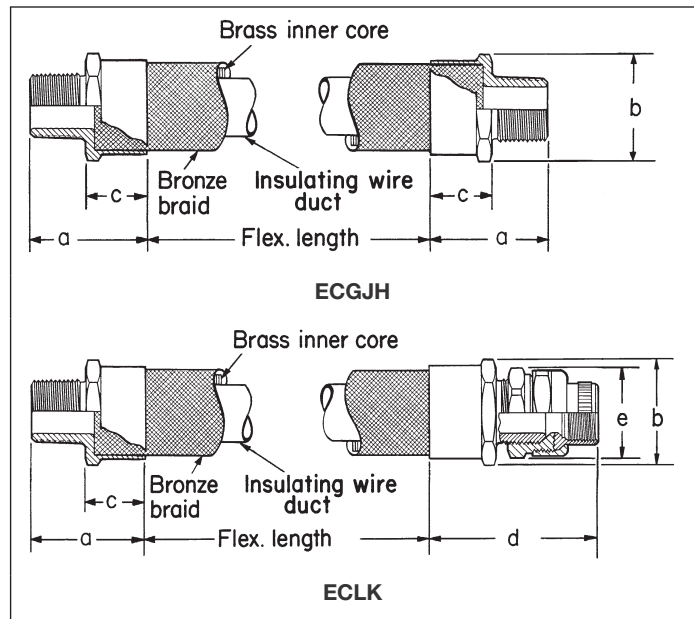

5F

## EXPLOSIONPROOF INSTALLATION INSTRUCTIONS



Ceiling



Wall



Pendant

Thank you for buying RAB lighting fixtures. Our aim is to design the best quality products to get the job done right. We'd like to hear your comments. Call the Marketing Department at 888-RAB-1000, or email: [marketing@rabweb.com](mailto:marketing@rabweb.com)

### IMPORTANT

**READ CAREFULLY BEFORE INSTALLING FIXTURE. RETAIN THESE INSTRUCTIONS FOR FUTURE REFERENCE.**

RAB fixtures must be wired in accordance with the National Electrical Code and all applicable local codes. Proper grounding is required for safety. This product must be installed in accordance with the applicable installation code by a person familiar with the construction and operation of the product and the hazards involved.

**WARNING: TO PREVENT IGNITION OF HAZARDOUS ATMOSPHERES, THE SUPPLY CIRCUIT SHOULD BE DISCONNECTED WHEN INSTALLING, RELAMPING OR PERFORMING ANY MAINTENANCE ON THE LUMINAIRE. DO NOT OVERTIGHTEN SCREWS. DO NOT DISASSEMBLE PRODUCT.**

**CAUTION: When installing luminaire in hazardous locations, check the operating temperature limits prior to installation to be sure it conforms to the environment temperature restriction and NEC classifications of the installation location. Check the fixture's metal nameplate for temperature (T) ratings.**

### PENDANT MOUNTING

**WARNING: Use conduit and connectors suitable for the application. Seal all conduit using approved NEC procedures and local codes.**

1. Pendant requires 1/2" or 3/4" NPT threaded conduit pipe (provided by others)
2. Feed supply wires through the pipe into the **EP Cap**. Wire connections must be made in **EP Cap**. See wiring details section.
3. Place wires back into **EP Cap**. Tighten **Inspection Plug** with a wrench.
4. Fully thread the **Globe Holder** onto the **EP Cap**. Tighten with the **Thumb screw**.
5. To install lamp, see Lamp Installation section.
6. Be sure to close any unused wiring entrances with closure plugs provided.

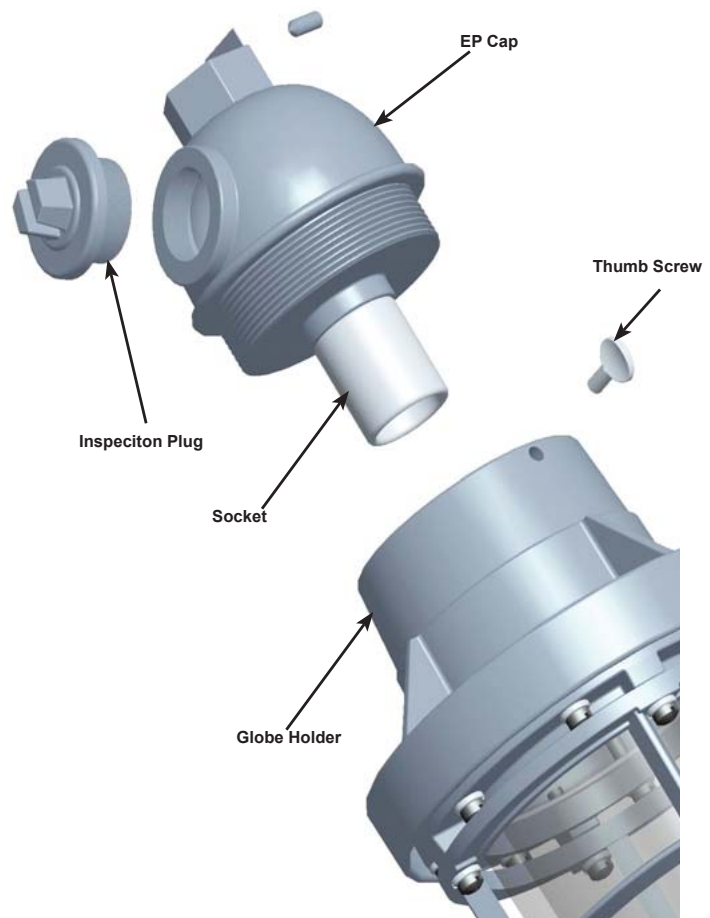

## EXPLOSIONPROOF INSTALLATION INSTRUCTIONS

### CEILING MOUNTING

**WARNING:** Use conduit and connectors suitable for the application. Seal all conduit using approved NEC procedures and local codes.

1. Do not separate screws on **EX Junction Box** and **E1 housing**.
2. Feed supply wires through the **EX Junction Box** and into the **E1 Housing**.
3. Mount **EX Junction Box** to surface using the **(2) Mounting Tabs**. Use hardware suitable for the mounting surface.
4. Wire connections must be made inside the **E1 Housing**. See wiring details section.
5. Place wires back into **E1 Housing**. Tighten **Inspection Plug** with a wrench.
6. To install lamp, see Lamp Installation section.
7. Fully thread the **Globe Holder** onto the **E1 Housing**. Tighten with the **Thumb screw**.
8. Be sure to close any unused wiring entrances with closure plugs provided.

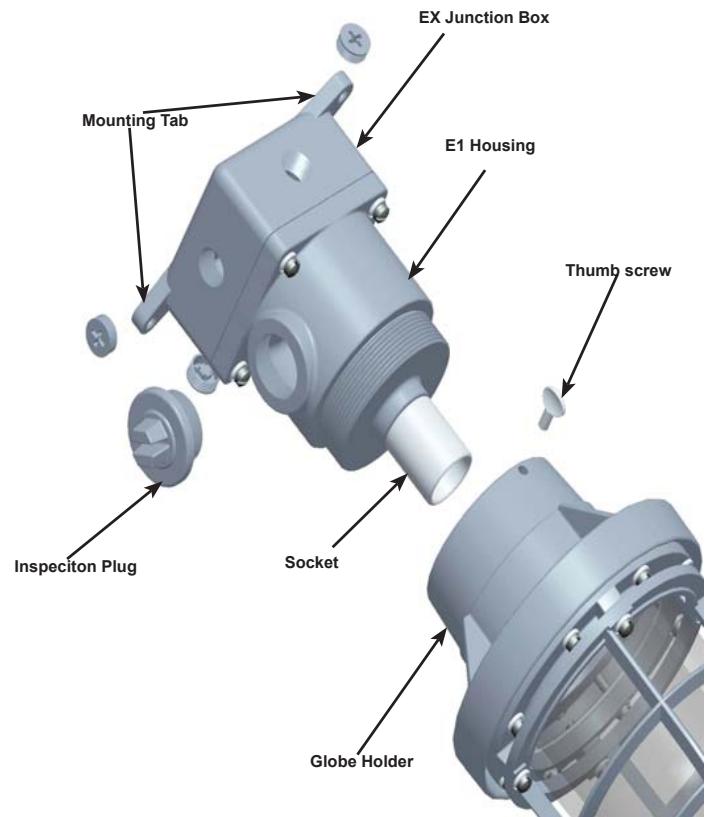

### BRACKET MOUNTING

**WARNING:** Use conduit and connectors suitable for the application. Seal all conduit using approved NEC procedures and local codes.

1. Do not separate **EX Junction Box**, **EB Bracket** and **E1 housing**.
2. Feed supply wires through the **EB Bracket** and **E1 Housing**. Wire connections must be made in **E1 Housing**. See wiring details section.
3. Mount **EX Junction Box** to surface using the **(2) Mounting Tabs**. Use hardware suitable for the mounting surface.
4. Place wires back into **E1 Housing**. Tighten **Inspection Plug** with a wrench.
5. To install lamp, see Lamp Installation section.
6. Fully thread the **Globe Holder** onto the **E1 Housing**. Tighten the **Thumb screw**.
7. Be sure to close any unused wiring entrances with closure plugs provided.

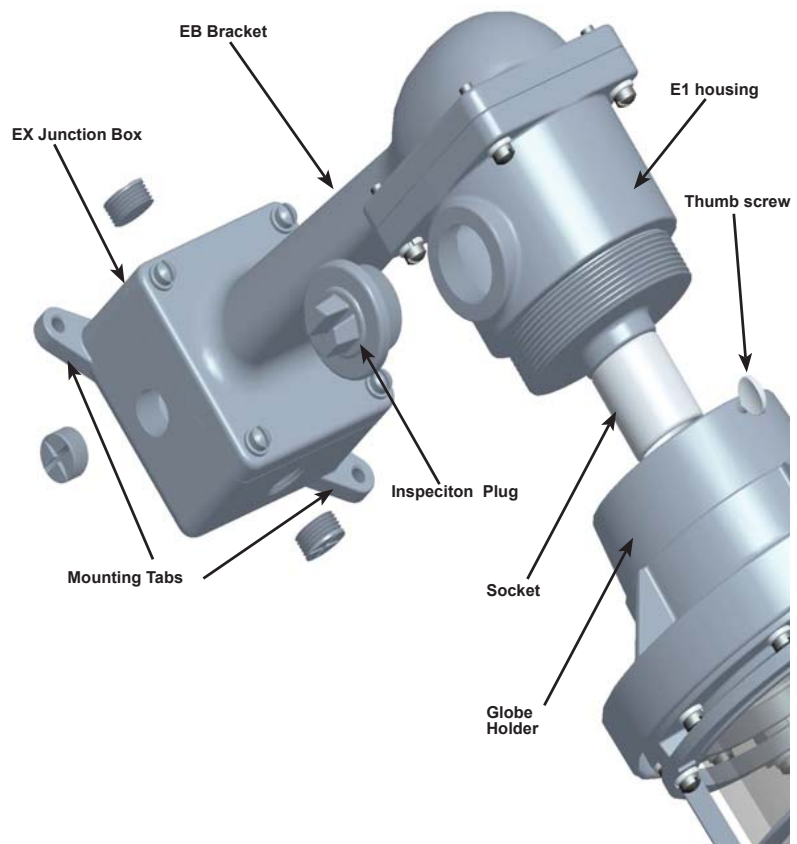



## EXPLOSIONPROOF INSTALLATION INSTRUCTIONS

### LAMP INSTALLATION/RE-LAMP

**CAUTION:** Prior to installing, check that the lamp is the correct wattage and size.

**WARNING:** The Globe is tempered glass, do not scratch or chip.

1. Disconnect power. Make sure fixture and lamp are cool enough to touch.
2. Loosen **Thumb Screw** and remove **Globe Holder Assembly** by unscrewing counter clockwise
3. Install/replace incandescent lamp. See Lamp Replacement section for more details.
4. Fully screw lamp into socket.
5. Replace **Globe Holder Assembly**. Screw on tightly and tighten **Thumb Screw**.

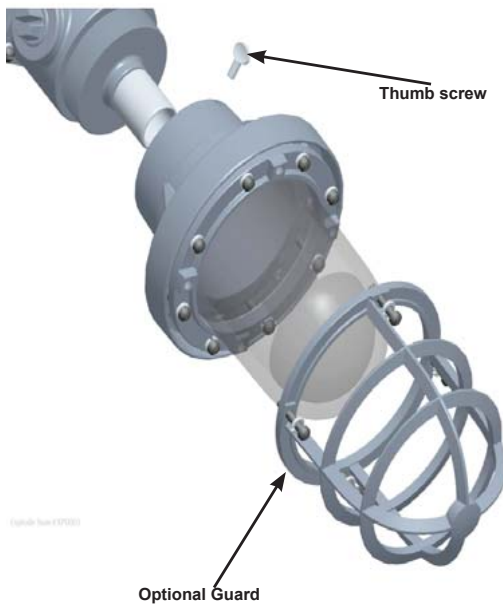

### LAMP REPLACEMENT

All fixtures are rated 250V maximum. See chart shown below for maximum lamp wattage:

Maximum Lamp Wattage(**)				
Hazardous Locations (*)		No Reflector	Standard Dome Reflector	Angle Reflector
Class	Group			
I	C & D	300W	300W	300W
II	E & F	200W	150W	200W
III	E, F & G	100W	-	150W

(\*) Fixtures Listed for use in Class II, Group G hazardous locations are also suitable for use in Class III locations.

(\*\*) Maximum lamp sizes are as follows  
 300W - PS25; 200W - PS25  
 150W - PS23; 100W - A19

### WIRING DETAILS

**CAUTION:** Make all connections in accordance with accepted NEC wiring procedures and local codes.

1. Connect the black fixture lead to HOT supply lead.
2. Connect the "COM" fixture lead to the COMMON supply lead.
3. Connect the Ground lead to supply ground.

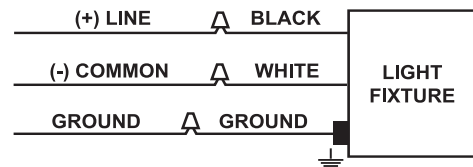

### CLEANING & MAINTENANCE

**CAUTION:** Be sure fixture temperature is cool enough to touch. Do not clean or maintain while fixture is energized.

1. Clean glass lens with non-abrasive glass cleaning solution.
2. As lamps age, light output diminishes. Mass relamping at regular intervals ensures full light output at the highest efficiency.
3. To re-lamp do not remove globe or guard. Remove entire globe holder assembly. See Lamp Installation section.

Note: These instructions do not cover all details or variations in equipment nor do they provide for every possible situation during installation, operation or maintenance.

# EP12

Explosionproof fixture for ceiling mounting. Set screw to stern prevents rotation. Cast aluminum housing, heat and impact resistant globe. Fits all incandescent lamps up to 300 watt PS-25. Lamp not supplied.

Color: Silver gray

Weight: 9.0 lbs

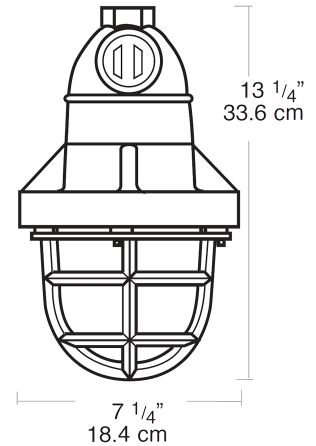

## Lamp Info

Type: PS-25  
Watts: 300W  
Shape/Size: N/A  
Base: N/A  
ANSI: N/A  
Hours: 0  
Lamp Lumens: 0  
Efficacy: N/A

## Ballast Info

Type: N/A  
120V: N/A  
208V: N/A  
240V: N/A  
277V: N/A  
Input Watts: 0W  
Efficiency: N/A

## Technical Specifications

### Housings:

Heavy cast aluminum. Unit withstands 1490 lbs. per square inch hydrostatic pressure during UL testing.

### Wiring:

Wiring is factory sealed. Inspection hole provides easy access to splice compartment.

### Globe:

Impact and heat resistant clear prismatic design affords excellent light control.

### Finish:

Our environmentally friendly polyester powder coatings are formulated for high-durability and long-lasting color, and contains no VOC or toxic heavy metals.

### Reflectors:

Heavy gauge aluminum with highly reflective white acrylic finish.

### Socket:

Medium base glazed porcelain. Leads pass through sealing compound that separates lamp chamber from wiring compartment. Heavy gauge nickel plated copper components. Spring loaded center contact.

### Refer to the catalog for Class and Division specifications:

.

### Hub Size:

1/2"

### Hub Count:

1.

### Guard not supplied:

.

### Weight:

11 lb / 5 kg.

### Patents:

RAB sensor and fixture designs are protected under U.S. and International Intellectual Property laws.

### Country of Origin:

Designed by RAB in New Jersey and assembled in the USA by RAB's IBEW Local 3 workers.

### Buy American Act Compliant:

This product is a COTS item manufactured in the United States, and is compliant with the Buy American Act.

### Recovery Act (ARRA) Compliant:

This product complies with the 52.225-21 "Required Use of American Iron, Steel, and Manufactured Goods-- Buy American Act-- Construction Materials (October 2010).

### Trade Agreements Act Compliant:

This product is a COTS item manufactured in the United States, and is compliant with the Trade Agreements Act.

### GSA Schedule:

This product is suitable for listing on the GSA Schedule of the US General Services in accordance with FAR Subpart 25.4.

# GUR Universal Outlet Box

Cl. I, Div. 1 & 2, Groups C,D  
Cl. II, Div. 1, Groups E,F,G  
Cl. II, Div. 2, Groups F,G  
Cl. III  
NEMA 3,4,7CD,9EFG

Explosionproof  
Dust-Ignitionproof  
Raintight  
Wet Locations

4F

## Application:

GUR conduit outlet boxes are installed within hazardous areas:

- to protect conductors in threaded rigid conduit
- to act as pull and splice boxes
- to connect lengths of conduit
- to provide access to conductors for maintenance and future system changes
- to change conduit direction
- where space is limited, such as underneath gasoline pumps

## Features:

GUR outlet boxes feature:

- neoprene O-ring standard in cover to meet NEMA 4/UL Type 4 requirements
- internal green ground screw
- five standard hubs with three pipe plugs included
- threaded cover opening
- recesses in cover to assist in cover tightening and removal
- smooth, integral hub bushing to protect conductor insulation when pulling
- compact design for confined spaces
- UL and cUL listing
- optional all-aluminum construction

## Standard Materials:

- Bodies – *Feraloy*® iron alloy
- Covers – copper-free aluminum

## Standard Finishes:

- *Feraloy* iron alloy – electrogalvanized with aluminum acrylic paint
- Aluminum – natural

## Certifications and Compliances:

- NEC/CEC:
  - Class I, Division 1 and 2, Groups C and D
  - Class II, Division 1, Groups E, F and G
  - Class III
  - Zone 1 and 2
- UL Standard 886
- cUL to CSA Standard C22.2 No. 30
- NEMA 4

## Options:

- Bodies – copper-free aluminum (add suffix -SA)

## Ordering Information

### Hub Size

1/2"  
3/4"  
1"

### Cat. #

GUR1  
GUR2  
GUR3



## Dimensions

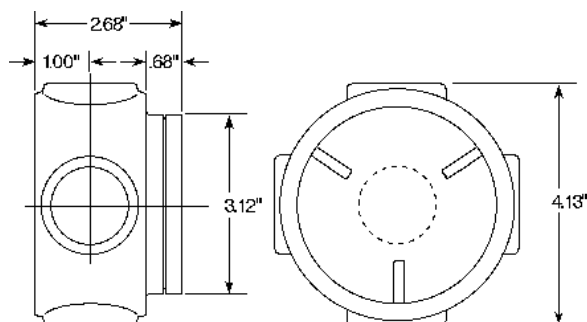

- \* 0.110" quick-disconnect connections.
- Includes mounting screws. Not UL recognized or CSA certified.

### Switch Boots



Shown Installed

	Each
For 3/4" Lg. x 1/2" Wd. Panel Cutout Switches	7395K91 \$2.46
For 1 1/8" Lg. x 13/32" Wd. Panel Cutout Switches	7395K93 2.74
For 1 1/8" Lg. x 9/16" Wd. Panel Cutout Switches with One Circuit	7395K92 2.74
For 1 1/8" Lg. x 9/16" Wd. Panel Cutout Switches with Two Circuits	7395K94 2.74

### Heavy Duty Rocker Switches



White Rocker



Illuminated Rocker

A durable steel housing holds up in tough environments. These rocker switches have solder lug connections and stainless steel retaining clips for mounting in a 1 1/4" Lg. x 3/4" Wd. panel cutout. Rated 10 amps @ 125 volts AC and 6 amps @ 30 volts DC. Maximum voltage is 250 AC and 30 DC. UL and C-UL recognized.

**Illuminated rocker** switches are lit on each side by a separate replaceable 28-volt bulb (included) and stay lit regardless of switch position. One side of the rocker has a green lens; the other has a red lens.

**Note:** Switches that stay switched are also known as maintained; switches that spring back are also known as momentary. Parentheses in the industry designation indicate momentary switch action.

No. of Circuits	When Switch Is		Switch Action	No. of Terminals	Industry Designation	White Rocker		Illuminated Rocker	
	Left, Circuit Is	Right, Circuit Is				Each	Each		
<b>Two Position</b>									
2	Off or On	On or Off	Stays Switched	10	DPDT ON-ON	7246K16	\$15.55	7246K11	\$20.70
2	Off or On	On or Off	Springs Back	10	DPDT ON-(ON)	7246K18	17.10	7246K13	22.58
<b>Three Position—Switch is Off in Center Position</b>									
2	Off or On	On or Off	Stays Switched	10	DPDT ON-OFF-ON	7246K17	16.70	7246K12	21.85
2	Off or On	On or Off	Springs Back to Center	10	DPDT (ON)-OFF-(ON)	7246K19	17.60	7246K14	22.75
2	Off or On	On or Off	Springs Back Right to Center	10	DPDT ON-OFF-(ON)	7246K21	17.60	7246K15	22.75

### High-Amp Rocker Switches



Designed for high currents, these switches mount in a 1 7/16" Lg. x 15/16" Wd. panel cutout (mounting hardware included) and have screw terminal connections. Rocker is white. UL recognized.

**AC-rated** switches are rated 30 amps @ 125 volts AC. Maximum voltage is 250 AC.

**DC-rated** switches are rated 30 amps @ 30 volts DC. Maximum voltage is 125 DC.

**Note:** Switches that stay switched are also known as maintained.

When Switch Is

AC Rated

DC Rated