

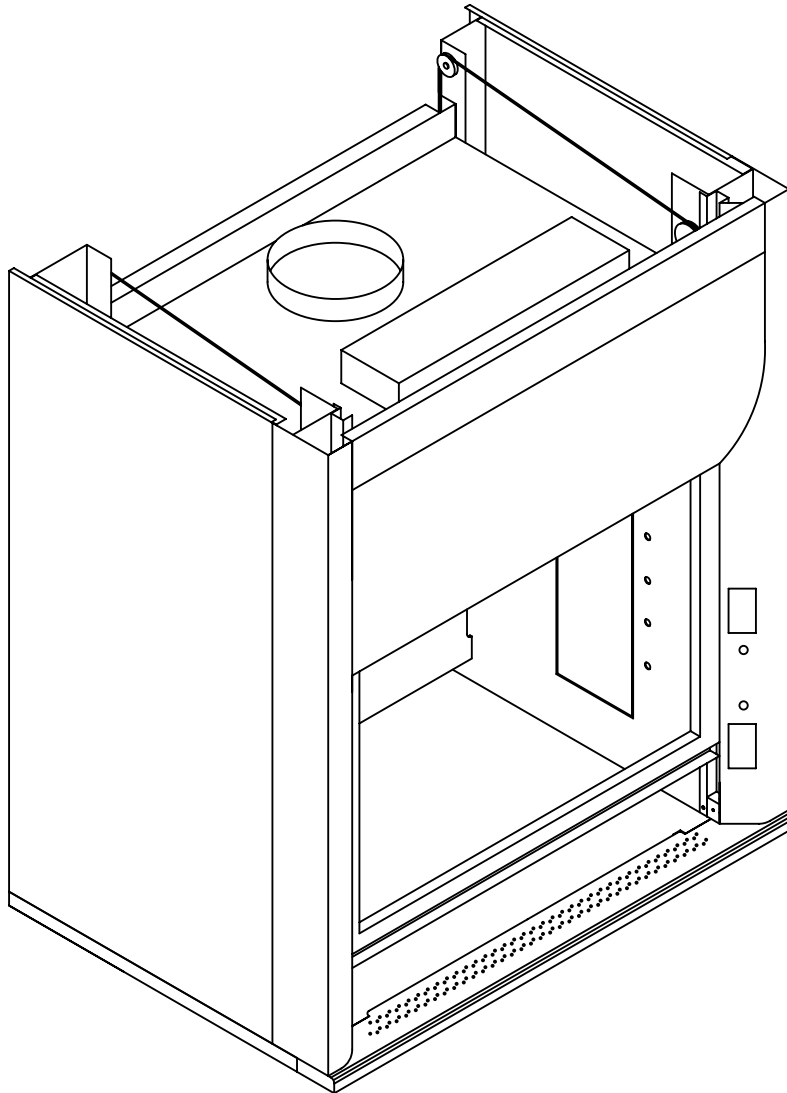

Fume Hood O&M



Solution Series & Eliminator Series
Fume Hoods

Operation and maintenance begins with the proper start up, normally provided by your Lab Manager, Classroom Supervisor or EH&S personnel. A typical laboratory operating procedure addresses practices such as those suggested below.

- Make sure the exhaust fan is operating prior to starting an experiment.
- Keep experiments and equipment 6" or more from the front edge of the sash.
- If possible, raise equipment off the counter top to facilitate air movement below.
- Wear protective clothing such as safety goggles, gloves, and lab coats.
- Keep the sash closed except when loading or unloading the experiment.
- Keep the sash window clean and clear.
- Immediately clean up and major spills occurring inside the fume hood.
- Remove all residues from the fume hood chamber once the experiment is complete.
- Keep the light fixtures clean and replace the bulbs whenever necessary.

It is recommended that a clear working environment be promoted for both safety and operation of the fume hood.

It is the responsibility of the user to consult with the Lab Manager or Classroom Supervisor for additional lab safety procedures and practices. When conducting an experiment within the fume hood, it is the user's responsibility to understand and follow the lab safety procedures and practices.

All spills inside the fume hood should be cleaned up immediately with a neutralizing compound as required by your facility manager. Spills must be flushed and cleaned thoroughly to ensure lab safety.

Weekly Maintenance

General maintenance or housekeeping should be done on a weekly basis. This consists primarily of cleaning the side walls, baffles, counter tops and sash of any dirt or debris that may have collected. All surfaces can be cleaned with a mild detergent and water. If a large amount of build up is present, a qualified laboratory technician should observe the contents and oversee the cleaning procedure to ensure the integrity and proper operation of the hood and the safety of lab personnel.

Monthly Maintenance

Glass, chain, sprocket, sash guides, and plumbing handles are the only parts that move on the fume hood. These items should be checked on a monthly basis to note and damage or excessive wear and tear. These parts should be replaced as soon as damage or excessive wear has been observed.

The sash glass should be replaced if there are any chips, cracks or scratches that prevent a clear view of the interior of the fume hood.

The cables on top of the fume hood should be replaced if there is damage to the protective coating which prevents smooth operation of the sash. Plumbing handles should turn only in a clockwise or counterclockwise direction. If the handles seem loose or wobbly, check the screw behind the index button or the cotter pin that connects the handle to the valve.

Annual Maintenance

The hoods must be balanced to maintain the proper air flow across the face of the fume hoods. This procedure should be performed on an annual basis to make sure all exhaust fans are performing properly, and proper air flow is being achieved. Contact your local HVAC contractor for assistance with balancing the air flow.

Additional Accessories

If additional accessories have been added to your specific fume hood, such as magnahelic gauges or air flow monitors, a separate manual specifically addressing those items has been supplied and should be consulted.

Stainless Steel Work Surfaces

Upon receipt of your order, please take care to inspect the products to be sure that they have been made to order, and that damage has not occurred in transit. There is a five day window to report any damage you should find. In this unlikely event, please contact us or the dealer that you purchased from, and we will assist you promptly.

Our stainless-steel countertops are made with a type 304 stainless steel, with a number 4, b-brushed finished. Countertops are guaranteed, under normal usage, for a one-year period from the date of receipt. This warranty is null and void if damage has occurred as a result of mistreatment or non-typical use of the product. All of our stainless steel products should be received in a shiny and new condition. To maintain that new appearance, we recommend using a stainless-steel cleaner and polish. Clean up spills and residue immediately to help maintain a new appearance. Consult with your safety officer regarding proper clean up procedures and disposal coating which prevents smooth operation of the sash.

Sash Operation

While operating the sash, DO NOT use excessive force to open the sash. Doing this can cause the chain/cable system to jump and cause the sash to sag, or not work entirely. If the sash becomes difficult to open, please make sure that all maintenance steps have been followed. In most cases, general maintenance will allow for the easy opening of the sash.

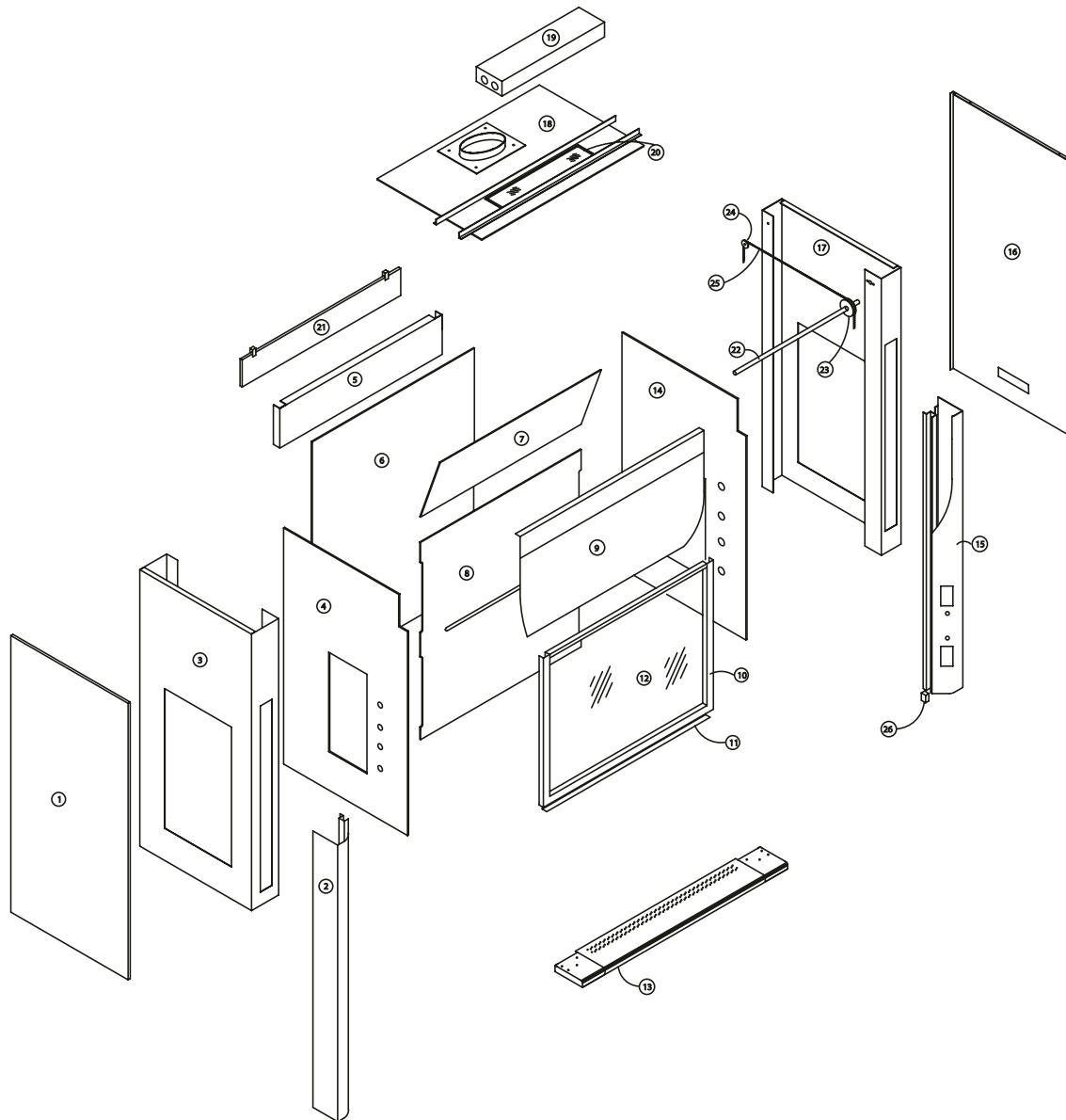

1	LH Exterior Metal Side Panel
2	LH Post Front
3	LH Frame Structural Support
4	LH Interior Polyresin Side Panel
5	Top Rear Reinforcement
6	Polyresin Back Panel
7	Upper Polyresin Baffle
8	Lower Polyresin Baffle
9	Front Panel

10	Tube Sash Frame w/ Glass Trim
11	Bottom Finger Lift
12	1/4" Clear Lami Safety Glass
13	Airfoil Assembly
14	RH Interior Polyresin Side Panel
15	RH Pose Front
16	RH Exterior Metal Side Panel
17	RH Frame Structural Support
18	Polyresin Top Panel

19	2-Tube T-8 Fluorescent Light
20	1/4" Clear Lami Light Glass
21	Sash Counterweight
22	Stainless Steel Cable Shaft
23	Front Sprocket for Sash Chain
24	Rear Sprocket for Sash Chain
25	#35 Roller Chain
26	Rubber Bumper (For Sash)

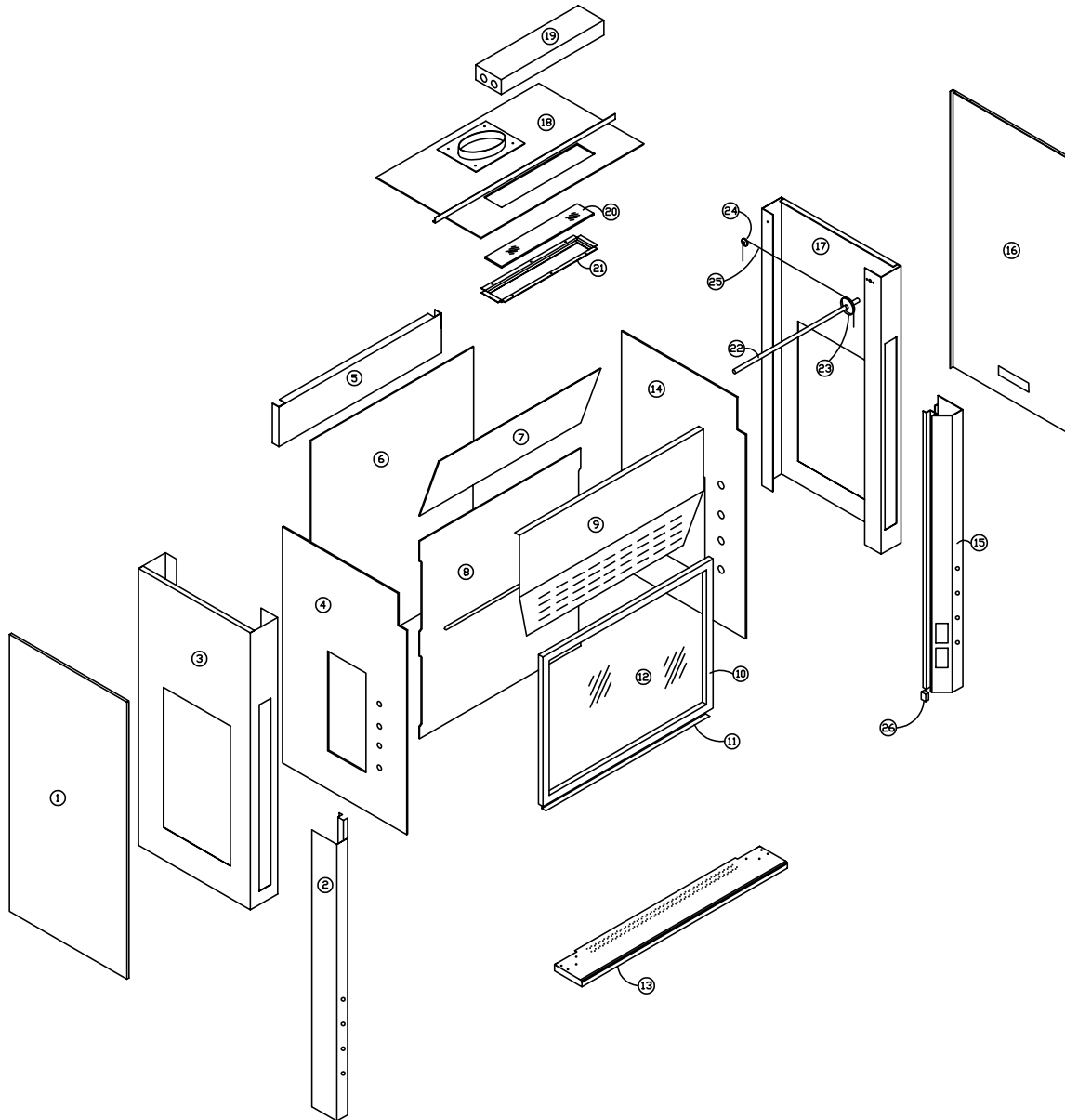

1	LH Exterior Metal Side Panel
2	LH Post Front
3	LH Frame Structural Support
4	LH Interior Polyresin Side Panel
5	Top Rear Reinforcement
6	Polyresin Back Panel
7	Upper Polyresin Baffle
8	Lower Polyresin Baffle
9	Front Panel

10	Tube Sash Frame w/ Glass Trim
11	Bottom Finger Lift
12	1/4" Clear Lami Safety Glass
13	Airfoil
14	RH Interior Polyresin Side Panel
15	RH Pose Front
16	RH Exterior Metal Side Panel
17	RH Frame Structural Support
18	Polyresin Top Panel

19	2-Tube T-8 Fluorescent Light
20	1/4" Clear Lami Light Glass
21	Light Glass Frame
22	Stainless Steel Cable Shaft
23	Front Sheave
24	2" DIA Steel Pulley
25	7x7 Steel Coated Sash Cable
26	Rubber Bumper (For Sash)

Ceiling Enclosures

The ceiling enclosures are available in two types: for standard fume hoods and also for those fume hoods utilizing the optional Air Chamber. Both enclosures conceal and protect the hood ductwork, electrical conduit and other supply lines.

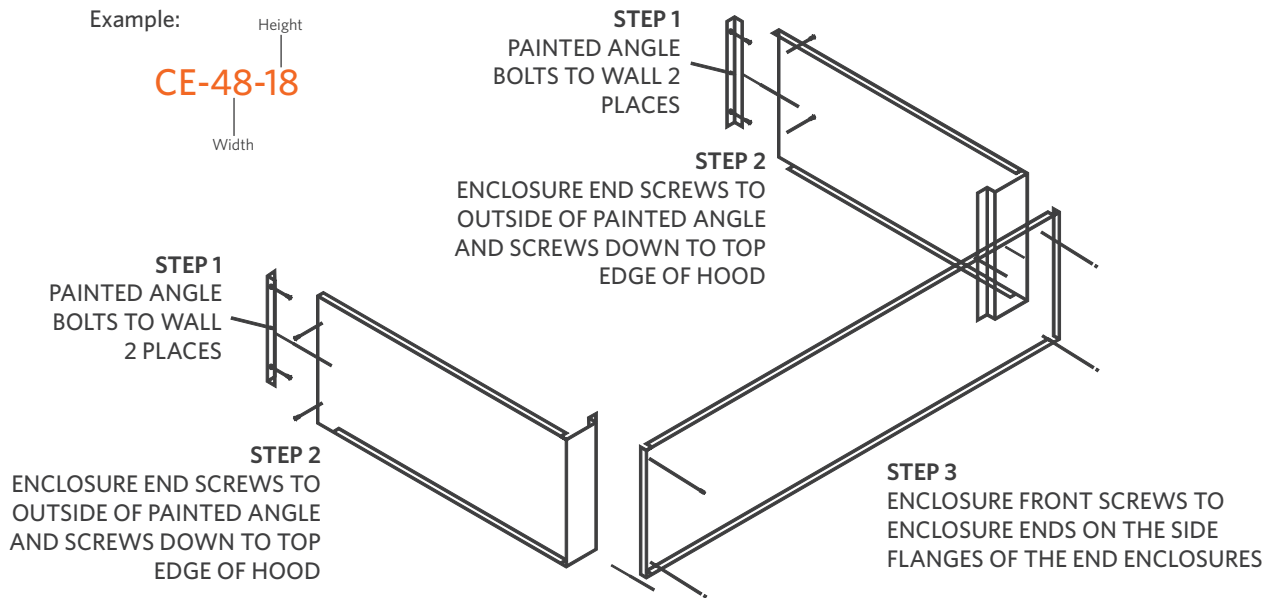

Finished Back

Finished backs are used to close off the back of the fume hood, giving it a finished look when located in the center of a room.

Example:

FINBACK-48

Width

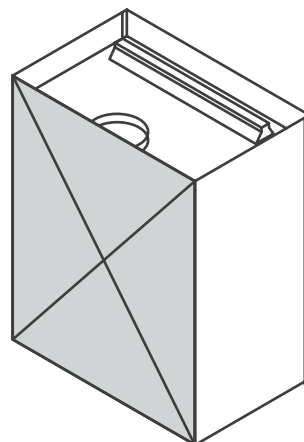

*Width will be the same
width as fume hood.

Pre-Wire service is completed in accordance with NEC and UL-1805 standards

Note: If the fume hood is not pre-wired, wiring in the field must be accomplished using UL listed electrical fixtures while observing NEC standards and local electrical codes.

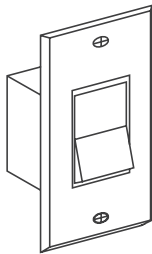
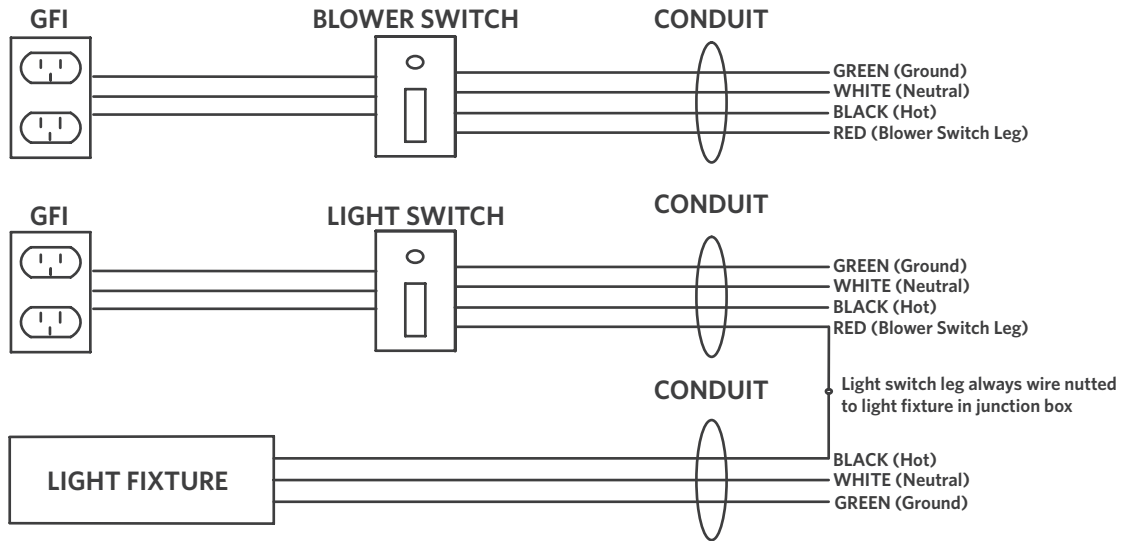

**Single Pole
15 Amp Light Switch
Standard Black Color
and Cover Plate
Part # LTSW**

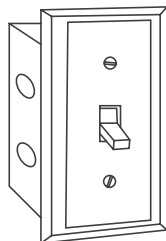

**Red Illuminated
Toggle Switch
with Black Cover Plate
Part # BLSW**

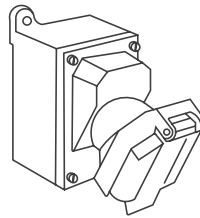

**Explosion Proof Outlet
Class 1, Group 1
Part # XPO**

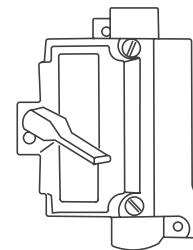

**Explosion Proof Switch
Class 1, Group 1
Part # XSW**

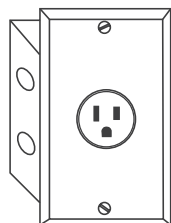

**208 Volt, 20 Amp
Single Pole Receptacle
230, 277 or other
available upon request
Part # 208**

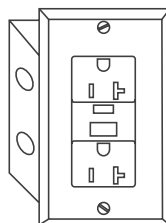

**120 Volt, 20 Amp Ground Fault
Interrupter (GFI)
Duplex Outlet
Standard Black color with cover
Part # GFI**



**Explosion Proof Light
Class 1, Group 1
Available in
Incandescent or fluorescent
Part # XPL**



A WILSONART COMPANY

EPOXY WORKSURFACES CARE & MAINTENANCE

Care and Maintenance Guidelines for Durcon Epoxy Worksurfaces

Durcon epoxy worksurfaces are durable, non-porous, monolithic, lab-grade products that are relatively unaffected by most chemicals, heat, flame and moisture. Its physical properties are resilient and seldom compromised – however they do require periodic care and maintenance throughout the life of the laboratory or facility to keep the surfaces looking like new. Whether you are a facility owner, manager, custodian or lab end user, following these guidelines will maintain the aesthetic appearance of your lab's worksurfaces.

STANDARD CARE

Durcon recommends instituting a regimen of monthly close inspections of all surfaces, sinks and joints, in addition to daily or weekly cleanings, to maintain a worksurface's original finish, and to help ensure a safe, uncontaminated working environment. The following list contains approved items you may want to have on-hand for regular cleaning, care and maintenance.

- Acetone or paint thinner
- Crystal Simple Green®
- White Scotch Brite® Pads (always use moist or wet)
- Finish oil (mineral oil)
- Murphy's Oil®
- Clean rags or sponges
- Chamois cloth
- Mild soap or household cleaner
- Two-part Smooth-On® epoxy grout

Note: Never use wax or polish containing wax, abrasive pads, powders or liquids (such as Soft Scrub) on epoxy worksurfaces or sinks, as dulling of the surface may occur.

Worksurface Care

Promptly clean up and wipe away all spills. Use acetone (where allowed) to thoroughly clean surfaces. Apply acetone and wipe away with a paper towel or clean rag. As an alternative, Crystal Simple Green® (or comparable household cleaning product) can be used as well.

An occasional application of finish oil or Murphy's Oil® can be used to restore the luster of a surface, but use in moderation as too much oil can cloud a surface.

- Apply a small amount of oil onto a clean rag, just enough to cover the surface area.
- Thoroughly rub the oil in, using a circular motion.
- Wipe away excess oil with a clean rag.
- A chamois can be used to buff the worksurface to the desired sheen.

Durcon Epoxy Sink Care

Laboratory sinks can present the greatest challenges for cleaning and maintenance. Sink basins can be used as a collection point for dirty and wet lab ware, leaving liquids, residue and chemicals on the surface for extended periods of time. Sink areas require more frequent inspections as well as a more thorough cleaning regimen than bench worktops. Sink inspections should assess all sink surfaces and joints in sink the area, including the outlet joint and the sink rim joint above and below the worksurface. Fill-in cracked or pitted joints immediately with two-part Smooth-On® epoxy grout to prevent leaking and damage to the supporting casework.

MARRING, SCRATCHES & STAINS

For more serious maintenance issues, it is important to first identify the problem before trying to remedy it. Below are several common issues and the recommended remedy for each.

Marring

Most metals are softer than epoxy worksurfaces, and can leave a mar if pulled across a worktop. Marring is the material from an object left on the surface that appears as a line and is smooth to the touch. Marring can almost always be removed with acetone or a mild cleaning product and elbow grease.

Always start with the softest cloth and weakest solution (soap and water) first, then work your way up as necessary. If marring persists, progress to a white Light Duty Scotchbrite® pad moistened with a stronger solution. Never use an abrasive pad dry, and always begin by applying a minimum amount of pressure, increasing to only what is required to remove the mar.

Scratches

Harder metals, abrasives and heavy or sharp items can dig into the surface resulting in a scratch. Scratches usually appear as a lighter shade of the worksurface and are rough to the touch. Scratches in epoxy resin are permanent, but do not affect the performance of a worksurface.

An aesthetic remedy a scratch is to fill-in the void with a black permanent marker. However, this option is unlikely to perfectly match the color and gloss of the surrounding worksurface.

Stained Surfaces

Staining occurs when chemicals are left to dry on a worksurface. Chemical stains usually lighten or bleach the surface, but may also roughen and even crack the surface. Like scratches, chemical stains are permanent and if too much damage has occurred, the top may need replacing.

Special Care Issues

Durcon epoxy products (especially glued-in sinks) are subject to thermal shock and may experience damage from liquid nitrogen or dry ice. Improper disposal of these materials may result in joint failure and/or sink fractures.

EPOXY WORKSURFACE CARE - QUICK LIST

The performance of Durcon epoxy worksurfaces will not be compromised by normal laboratory use. Maintaining the appearance depends upon practicing regular care and maintenance.

Durcon recommends posting the list of DO'S and DON'TS on the opposite side of this page around the lab and near cleaning supplies to ensure everyone is informed of these best practices.

Best Practices for cleaning and caring for your epoxy resin worksurfaces



- ✓ **DO** immediately clean up any liquid or dry spill from a worksurface.
- ✓ **DO** place a trivet under hot containers and components.
- ✓ **DO** immediately extinguish flames on a worksurface.
- ✓ **DO** apply a thin coat of finish oil or Murphy's Oil[®] periodically.
- ✓ **DO** educate users on the proper care of epoxy resin worksurfaces.

Following these simple guidelines, your Durcon epoxy worksurfaces will maintain their aesthetics for the life of the laboratory or facility. Please take time to share this document with lab users and cleaning personnel, and institute a regular maintenance schedule to help ensure the safety and appearance of your lab. If you have further questions, please contact our Customer Service team at: [✉ samples@durcon.com](mailto:samples@durcon.com)
☎ 1-512-595-8000



- ✗ **DO NOT** drag items across a worksurface.
- ✗ **DO NOT** cut, chop, strike or drop items directly on a worksurface.
- ✗ **DO NOT** use abrasive sandpaper or metallic scouring pads on a worksurface or sink.
- ✗ **DO NOT** store chairs on top of a worksurface without protective covering such as cardboard.
- ✗ **DO NOT** melt dry ice with hot water directly on a worksurface or sink as the thermal shock may break joints or cause a fracture.
- ✗ **DO NOT** use wax (or a polish containing wax) on a worksurface.



WaterSaver

INNOVATIVE PRODUCTS FOR RESEARCH

Installation, Operation and Maintenance Guide:

Laboratory Service Fixtures and Safety Equipment





To Our Customers:

For over sixty years, WaterSaver Faucet Co. has set the standard for quality in faucets, valves and safety equipment for science laboratories. Our products are carefully designed and manufactured to provide exceptional durability and performance. However, in order to provide this durability and performance, our products must be installed correctly, operated properly, inspected regularly and maintained periodically.

To assist in the installation, operation and maintenance of our products, we have developed this "IO&M Guide." This Guide provides information on installation procedures, repair and replacement parts and troubleshooting techniques for our products.

When ordering WaterSaver parts, please note the following:

1. Part numbers beginning "HK" (handle kit) are a complete assembly consisting of a valve unit, packing nut, handle and index button. These assemblies are typically used to convert a faucet from one type of handle to another, or for complete rebuilding of the faucet or valve. Handle kits are sold individually.
2. Part numbers ending in "R" are available in package quantities only. The quantity contained in the package is indicated.
3. Parts that are visible when installed (such as packing nuts and handles) are furnished with a polished chrome plated finish as standard. Special finishes (such as satin chrome finish with clear epoxy coating, satin nickel finish with clear epoxy coating and colored powder coated finishes) are available at additional cost. *Please specify if a finish other than polished chrome is required.*

Repair and replacement parts are available on a 24-hour basis through the WaterSaver Parts Hotline. Our product specialists are available to answer questions and provide technical support. Call 1-800-WSF-PART to take advantage of this service.

WaterSaver Faucet Co. is dedicated to providing quality products and service. We trust that you will let us know if we can be of assistance in any way.

Steven A. Kersten
President

Contents

Laboratory Service Fixtures

Water Fixtures

Renewable Units for Water Fixtures.....	3-11
Handle/Unit Kits for Water Fixtures.....	12-15
Self-Closing Renewable Units for Water Fixtures	16-17
Renewable Units for Foot-Operated Valves	18

Pure Water Fixtures

Renewable Units for Pure Water Fixtures.....	19
Handle/Unit Kits for Pure Water Fixtures	20-25
Gooseneck Components	26

Vacuum Breakers

Components for Vacuum Breakers.....	27-28
Guidelines for Vacuum Breaker Installation, Operation and Maintenance	29-31
Needle/Fine Control Needle/Steam Valves	32-33
Inlet Components	34-35

Laboratory Safety Equipment

Spray Heads	36
Shower Heads.....	37
Shower Valves and Actuators.....	38
Bowls and Drain Fittings.....	39
Eyewash and Drench Hose Components	40
Squeeze Valves	41
Signs	42

Introduction



WaterSaver faucets utilize an interchangeable unit or cartridge that is standardized across the product line. The unit contains all working components of the water faucet or valve. There are no moving parts in the faucet or valve body itself to wear out. As a result, WaterSaver water fittings are virtually everlasting.

Key features of the WaterSaver renewable unit are:

- The unit has outer serrations or splines to lock the unit in position in the faucet body. The unit cannot rotate or turn as the faucet is used. The handles of the faucet will maintain position, even with lever or wrist blade handles.
- The valve seat is machined from solid stainless steel bar stock. The main wearing component of the valve is thus ultra-hard and corrosion resistant for superior durability.
- A hard rubber valve disc provides positive shut-off of the water flow. The valve does not have a soft or “spongy” feel that reduces the ability to meter the water flow.
- The valve stem is sealed with a molded TFE packing. The packing prevents leakage over hundreds of thousands of cycles. An adjustable packing nut permits take up of wear.

The WaterSaver renewable unit has been in use since the late 1940s, and has provided high performance and durability in literally millions of faucets. The overall design and dimensions of the unit have never changed. As a result, every WaterSaver faucet ever made can use the same renewable unit that goes into every faucet we make today.

WaterSaver renewable units are manufactured in a variety of styles and configurations for the many applications in which they are used. These styles and configurations are described below:

- 1. Manual vs. Self-Closing Control.** Typical laboratory faucets and valves are manufactured with a renewable unit that has manual (also called compression) control. The unit is manually opened and manually closed by turning the valve handle. However, in certain applications, it is desirable to have a faucet with a self-closing valve and handle. WaterSaver therefore also manufactures renewable units with a spring-loaded valve mechanism. The faucet closes automatically when the handle is released. WaterSaver manual and self-closing units are dimensionally identical and therefore interchangeable. Faucets can be converted from manual to self-closing control, and vice versa, simply by changing the faucet cartridge.
- 2. Round Serrated Stem vs. Tapered Square Stem.** The WaterSaver renewable unit was originally manufactured with a round serrated stem end. Handles had a matching round serrated broach to fit on the stem. In 1991, we changed to a valve stem with a tapered square end. Handles were also changed to have a matching female taper. The tapered square end provides a much more solid, durable fit between the stem and handle. However, we still offer renewable units and stems with the round serrated end (the BNV100 series) for use in maintaining older faucets.
- 3. Right Hand Thread vs. Left Hand Thread.** A typical faucet or valve is opened by rotating the handle in a counterclockwise direction. The faucet or valve is closed by turning the handle in the opposite (clockwise) direction. This rotation is called “right hand” construction, since the thread on the valve stem is a right hand thread. The vast majority of faucets manufactured by WaterSaver work in this way. However, when faucets are furnished with wrist blade or lever handles, it is preferable to have the handles open in opposite directions. For example, on an L400 series deck mounted mixing faucet, both handles should open by rotating up and close by rotating down. This requires that the valve mechanisms open in opposite directions. One of the valve mechanisms must therefore be furnished with a valve unit that has a reversed (i.e. left hand) thread. The unit with the left hand thread will open in the clockwise direction and close in a counterclockwise direction. The left hand unit is typically, though not always, installed on the cold water side of the faucet.

- 4. 120 Degree vs. 90 Degree Rotation.** Typical WaterSaver renewable units rotate approximately 120 degrees from the closed to open position. However, when a faucet is furnished with wrist blade or lever handles, it is advantageous for the handle to go from closed to open in a 90 degree rotation. This more limited rotation prevents the handles from hitting the counter or a backsplash behind the faucet. WaterSaver therefore offers the BNV200-90 series renewable units for use in faucets with wrist blade or lever handles.
- 5. Adjustable Volume Control.** The original WaterSaver renewable unit incorporated an adjustable volume control device. This device consists of a small round cap or thimble held in place by a set screw. By loosening the set screw and rotating the thimble, the user can adjust the size of the inlet port through which the water passes as it enters the valve. By opening or closing the port, the user can compensate for high water pressure or conserve water. Effective in 1985, the adjustable volume control device was changed from a standard to an optional feature of our products. Renewable units with the suffix "AC" include the adjustable volume control feature.
- 6. Tin-Lined Units.** Faucets and valves for distilled, deionized and purified water must be manufactured using inert materials that are in contact with the water. These inert materials protect the purity of the water, as well as prevent the purified water from corroding the faucet or valve itself. WaterSaver manufactures faucets and valves for purified water in tin-lined brass, PVC, polypropylene, polypropylene-lined brass, PVDF-lined brass and stainless steel. This wide selection of materials permits the use of products that meet the requirements of the particular application. Faucets and valves that are tin-lined brass use the same renewable unit as all

WaterSaver faucets. However, for purified water applications, the brass components of the unit are coated with a layer of pure tin. To order such units or components, add the suffix "TL" to the part number.

- 7. Check Valve.** WaterSaver offers renewable units with an internal check valve. The purpose of the check valve is to prevent backflow of water upstream of the valve. This can be used to prevent cross-mixing of hot and cold water when the faucet is opened for a long period of time and the outlet may be closed. This can occur on units such as pre-rinse units where there is a self-closing valve downstream of the faucet valves. All WaterSaver pre-rinse units are furnished with renewable units with internal check valves. To order a renewable unit with an internal check valve, add the suffix "CV" to the part number.
- 8. Ceramic Disc Units.** The original WaterSaver renewable unit is based on a compression valve design. The valve operates by means of a rubber disc that is compressed against a valve seat. When the handle is turned to open the faucet, the disc moves up off the seat, thus opening the waterway. When the handle is turned to close the valve, the disc is moved down to recompress against the valve seat. As an alternative to this type of construction, WaterSaver offers units that utilize rotating ceramic discs to control the water flow. The unit has two flat ceramic discs, each of which has a hole or port in it. When the handle is turned, the upper disc rotates, allowing the orifice in the upper disc to align with the orifice in the lower disc and opening the waterway. Units with rotating ceramic discs are dimensionally the same as, and thus interchangeable with, the standard WaterSaver compression renewable unit.

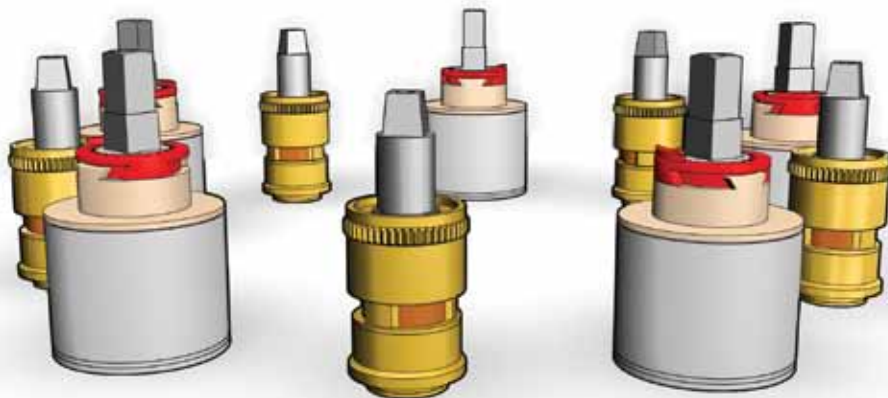

- **BNV100** Renewable Unit, Compression Control, Round Serrated Stem, Right Hand Thread
- **BNV100LH** Renewable Unit, Compression Control, Round Serrated Stem, Left Hand Thread

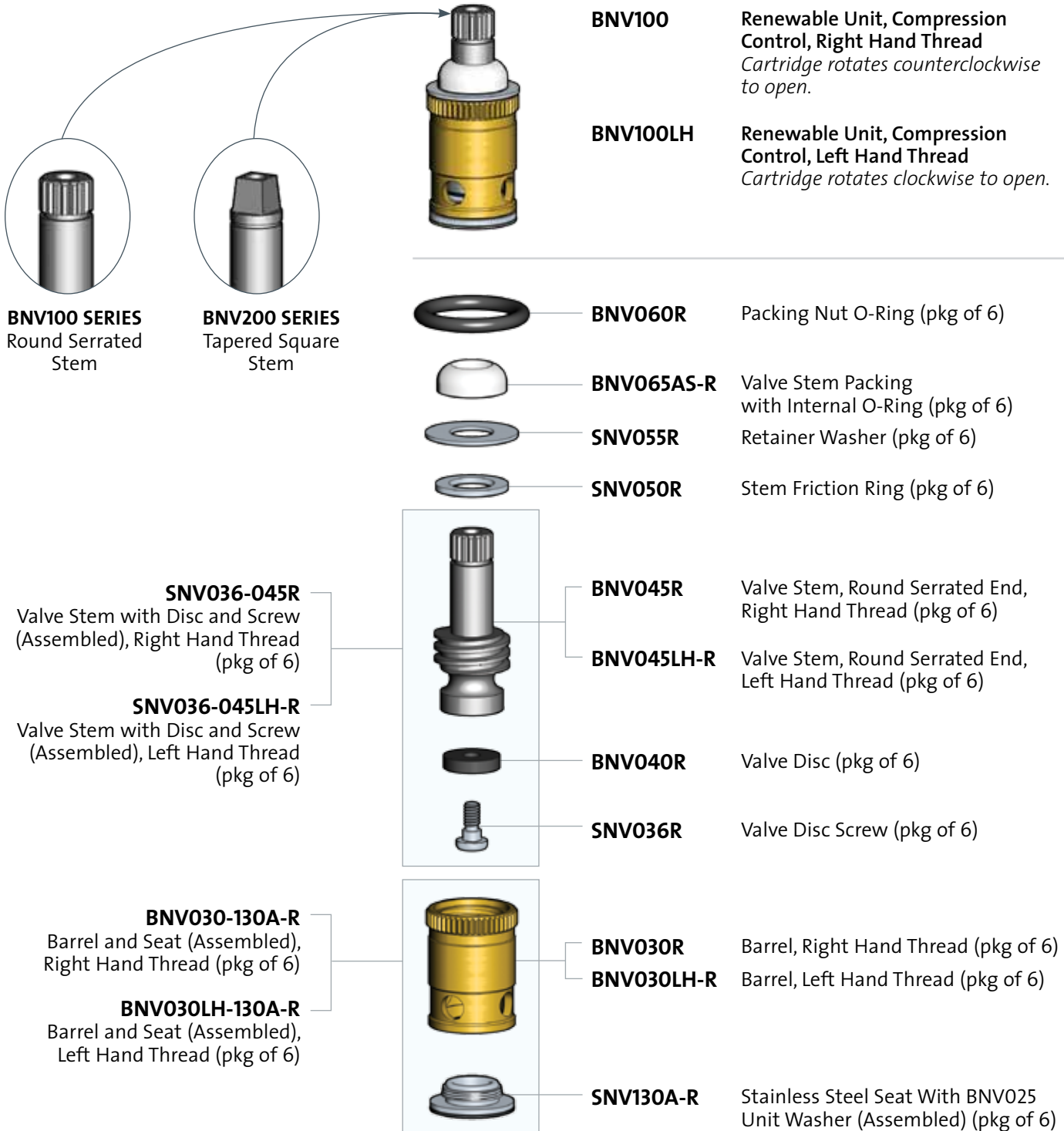



- **BNV100AC** Renewable Unit, Compression Control, Round Serrated Stem, Right Hand Thread, with Adjustable Volume Control
- **BNV100AC-LH** Renewable Unit, Compression Control, Round Serrated Stem, Left Hand Thread, with Adjustable Volume Control

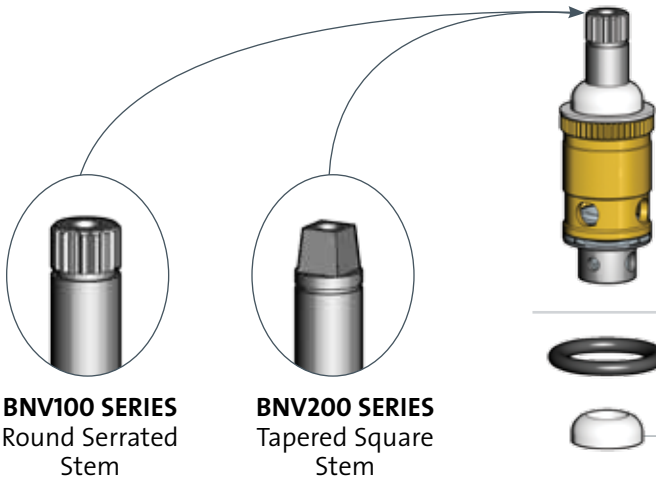

BNV100AC Renewable Unit, Compression Control, Right Hand Thread, with Adjustable Volume Control
Cartridge rotates counterclockwise to open.

BNV100AC-LH Renewable Unit, Compression Control, Left Hand Thread, with Adjustable Volume Control
Cartridge rotates clockwise to open.

BNV100 SERIES
Round Serrated Stem

BNV200 SERIES
Tapered Square Stem



BNV060R Packing Nut O-Ring (pkg of 6)



BNV065AS-R Valve Stem Packing with Internal O-Ring (pkg of 6)



SNV055R Retainer Washer (pkg of 6)



SNV050R Stem Friction Ring (pkg of 6)

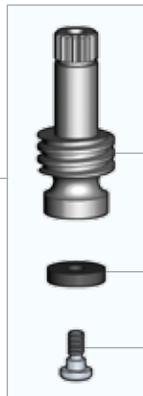

SNV036-045R
Valve Stem with Disc and Screw (Assembled), Right Hand Thread (pkg of 6)

BNV045R Valve Stem, Round Serrated End, Right Hand Thread (pkg of 6)

SNV036-045LH-R
Valve Stem with Disc and Screw (Assembled), Left Hand Thread (pkg of 6)

BNV045LH-R Valve Stem, Round Serrated End, Left Hand Thread (pkg of 6)



BNV040R Valve Disc (pkg of 6)



SNV036R Valve Disc Screw (pkg of 6)

SNV005-030R
Barrel and Seat with Adjustable Volume Control (Assembled), Right Hand Thread (pkg of 6)

BNV030R Barrel, Right Hand Thread (pkg of 6)

SNV005-030LH-R
Barrel and Seat with Adjustable Volume Control (Assembled), Left Hand Thread (pkg of 6)

BNV030LH-R Barrel, Left Hand Thread (pkg of 6)



SNV015R Stainless Steel Seat for Adjustable Volume Control (pkg of 6)



BNV025R Unit Washer (pkg of 6)



BNV010R WaterSaver Volume Control (pkg of 6)



SNV005R Set Screw (pkg of 6)

BNV200 Renewable Unit, Compression Control, Tapered Square Stem, Right Hand Thread

Note: For use in faucets with four-arm handles.

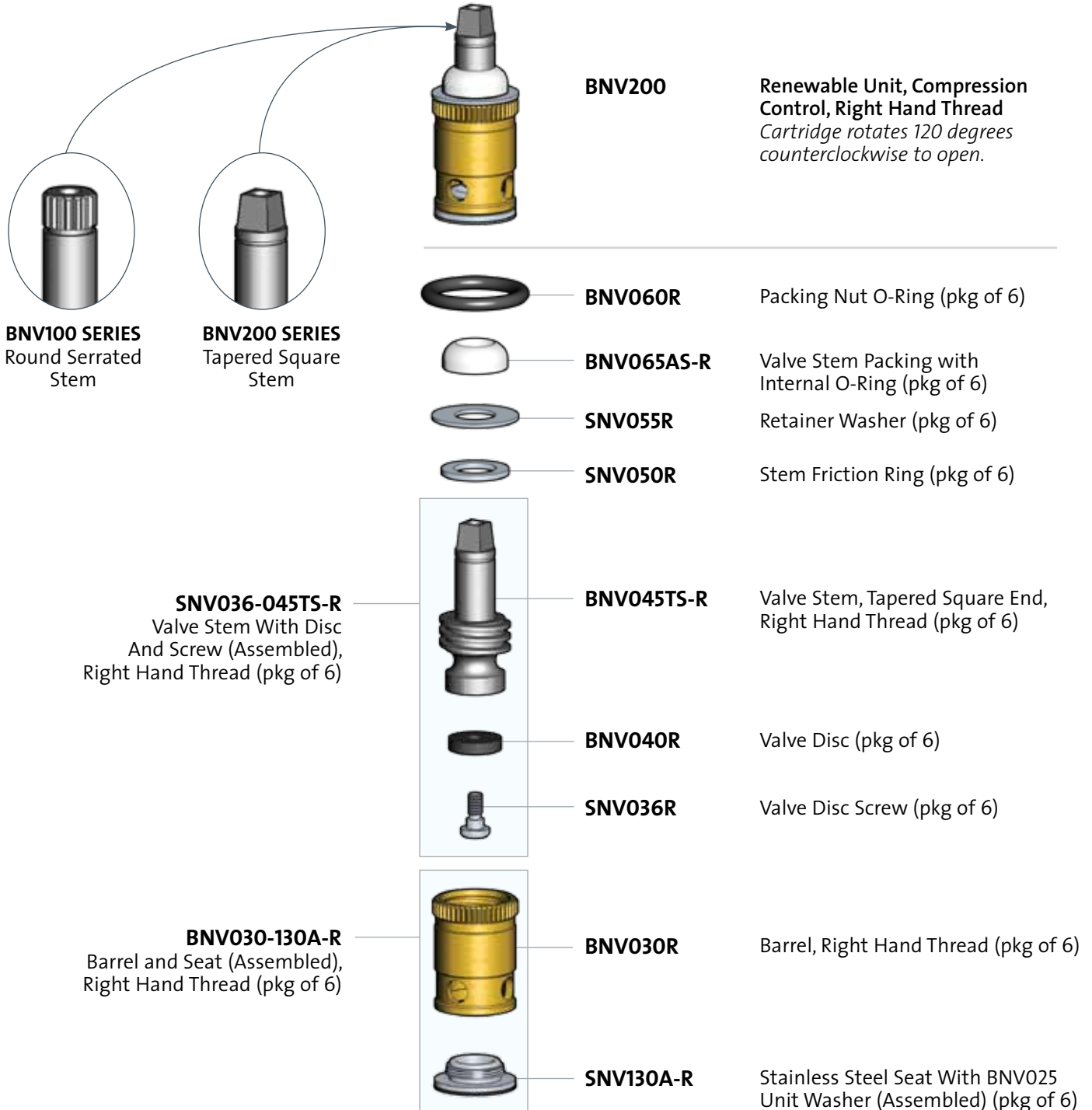



- **BNV200-90** Renewable Unit, Compression Control, Tapered Square Stem, Right Hand Thread, 90 Degree Rotation
- **BNV200LH-90** Renewable Unit, Compression Control, Tapered Square Stem, Left Hand Thread, 90 Degree Rotation

Note: For use in faucets with wrist blade and lever handles.

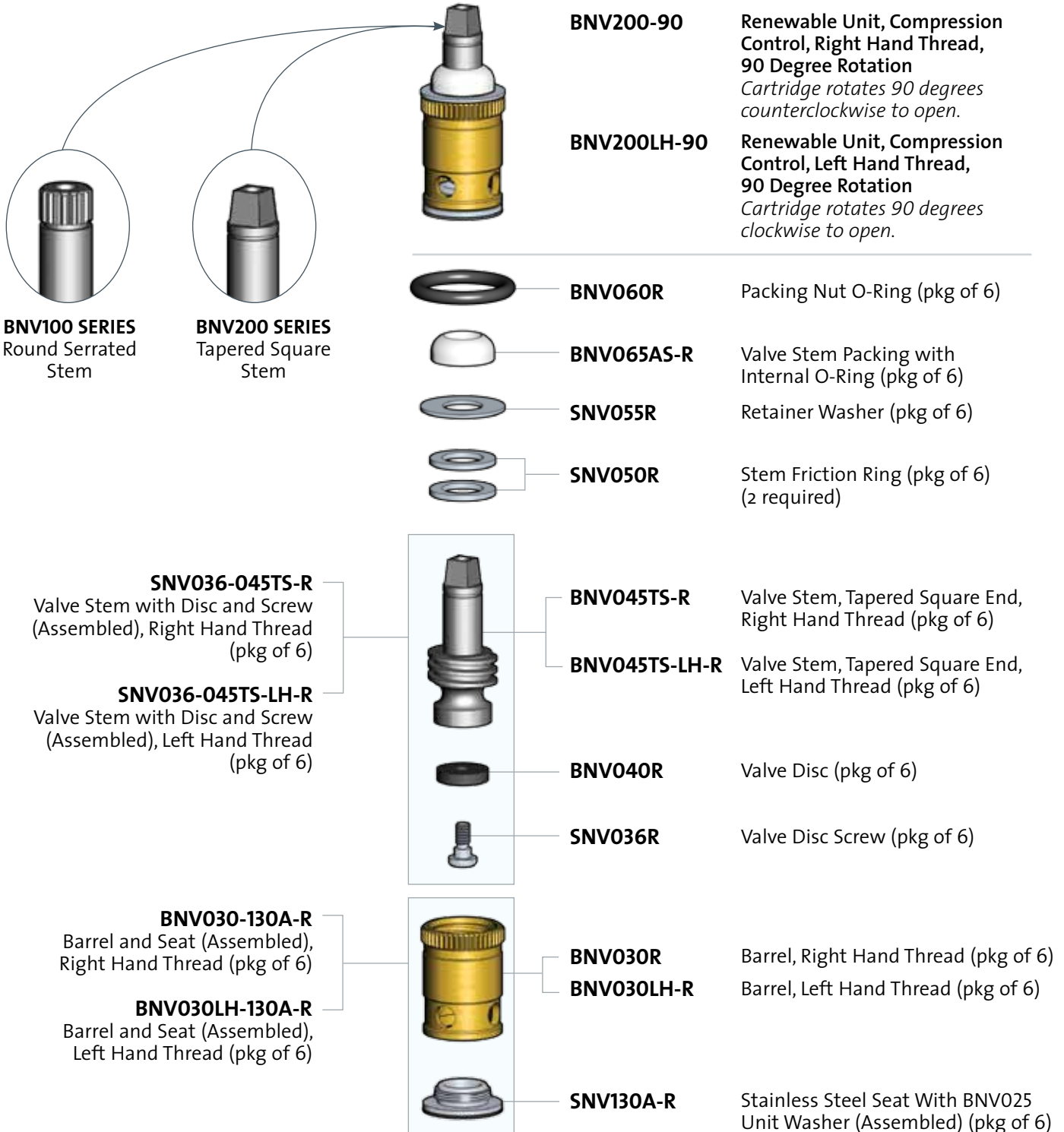

- **BNV200AC** Renewable Unit, Compression Control, Tapered Square Stem, Right Hand Thread, with Adjustable Volume Control

Note: For use in faucets with four-arm handles.

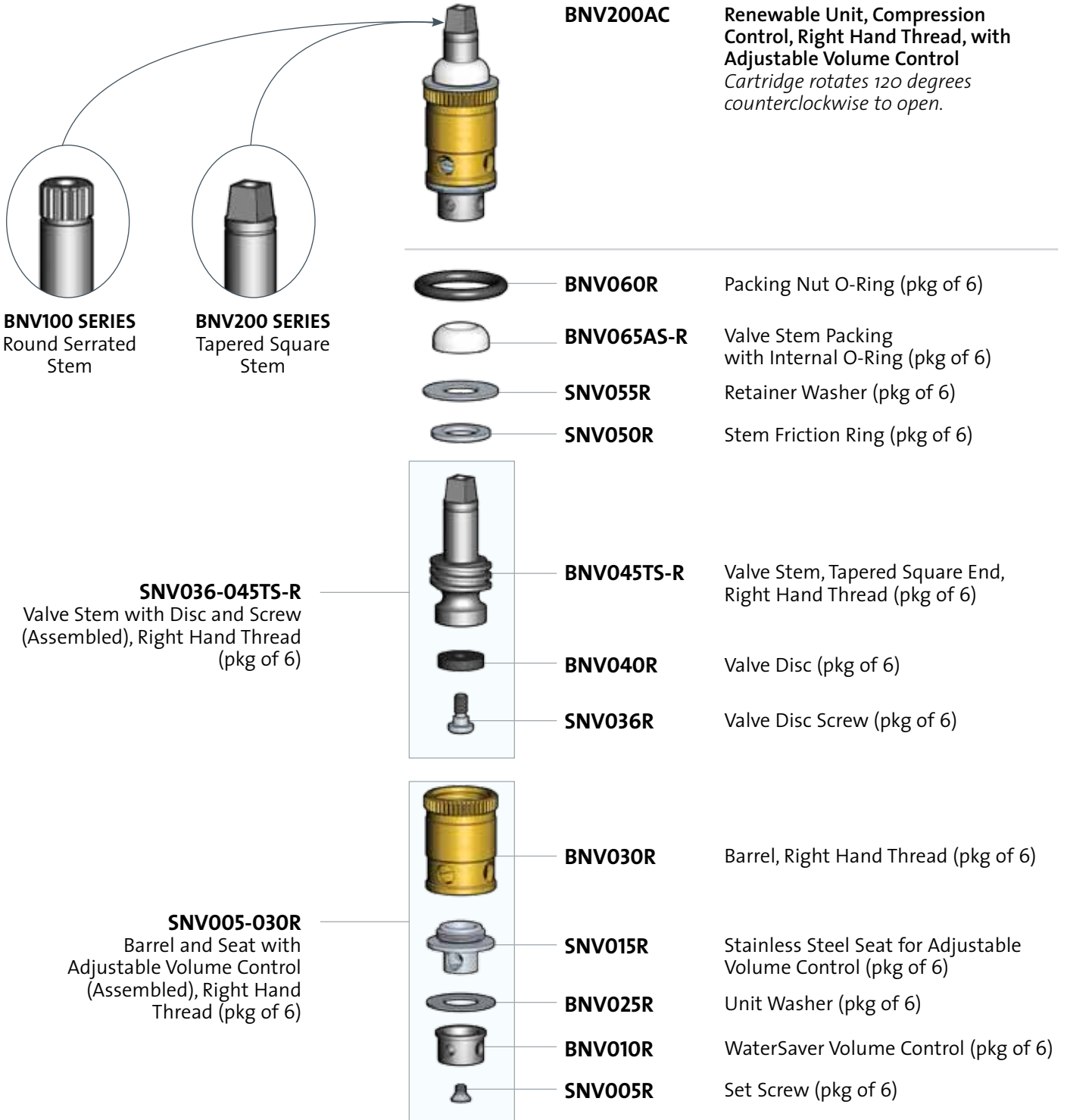



- **BNV200AC-90** Renewable Unit, Compression Control, Tapered Square Stem, Right Hand Thread, 90 Degree Rotation, with Adjustable Volume Control
- **BNV200AC-LH-90** Renewable Unit, Compression Control, Tapered Square Stem, Left Hand Thread, 90 Degree Rotation, with Adjustable Volume Control

Note: For use in faucets with wrist blade and lever handles.

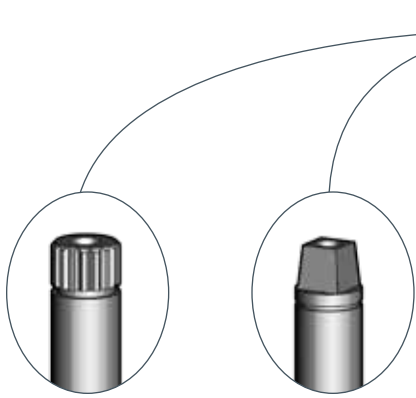

BNV100 SERIES
Round Serrated
Stem

BNV200 SERIES
Tapered Square
Stem



BNV200AC-90 Renewable Unit, Compression Control, Right Hand Thread, with Adjustable Volume Control
Cartridge rotates 90 degrees counterclockwise to open.

BNV200AC-LH-90 Renewable Unit, Compression Control, Left Hand Thread, with Adjustable Volume Control
Cartridge rotates 90 degrees clockwise to open.



BNV060R Packing Nut O-Ring (pkg of 6)



BNV065AS-R Valve Stem Packing with Internal O-Ring (pkg of 6)



SNV055R Retainer Washer (pkg of 6)



SNV050R Stem Friction Ring (pkg of 6)
(2 required)



SNV036-045TS-R
Valve Stem with Disc and Screw
(Assembled), Right Hand Thread
(pkg of 6)

BNV045TS-R Valve Stem, Tapered Square End,
Right Hand Thread (pkg of 6)

SNV036-045TS-LH-R
Valve Stem with Disc and Screw
(Assembled), Left Hand Thread
(pkg of 6)

BNV045TS-LH-R Valve Stem, Tapered Square End,
Left Hand Thread (pkg of 6)



BNV040R Valve Disc (pkg of 6)



SNV036R Valve Disc Screw (pkg of 6)



SNV005-030R
Barrel and Seat with
Adjustable Volume Control
(Assembled), Right Hand
Thread (pkg of 6)

BNV030R Barrel, Right Hand Thread
(pkg of 6)

BNV030LH-R Barrel, Left Hand Thread
(pkg of 6)

SNV005-030LH-R
Barrel and Seat with
Adjustable Volume Control
(Assembled), Left Hand
Thread (pkg of 6)



SNV015R Stainless Steel Seat for Adjustable
Volume Control (pkg of 6)



BNV025R Unit Washer (pkg of 6)



BNV010R WaterSaver Volume Control
(pkg of 6)



SNV005R Set Screw (pkg of 6)

○ **BNV300** Ceramic Disc Renewable Units



BNV300-180

Ceramic Disc Renewable Unit
Cartridge rotates 180 degrees counter clockwise to open.



BNV300-90

Ceramic Disc Renewable Unit
Cartridge rotates 90 degrees counter clockwise to open.



BNV300LH-90

Ceramic Disc Renewable Unit
Cartridge rotates 90 degrees clockwise to open.



BNV400

Ceramic Disc Renewable Unit for Single Handle Mixing Faucets



○ **HK013-200** Handle/Unit Kit with BA013TS Four Arm Handle and BNV200 Renewable Unit

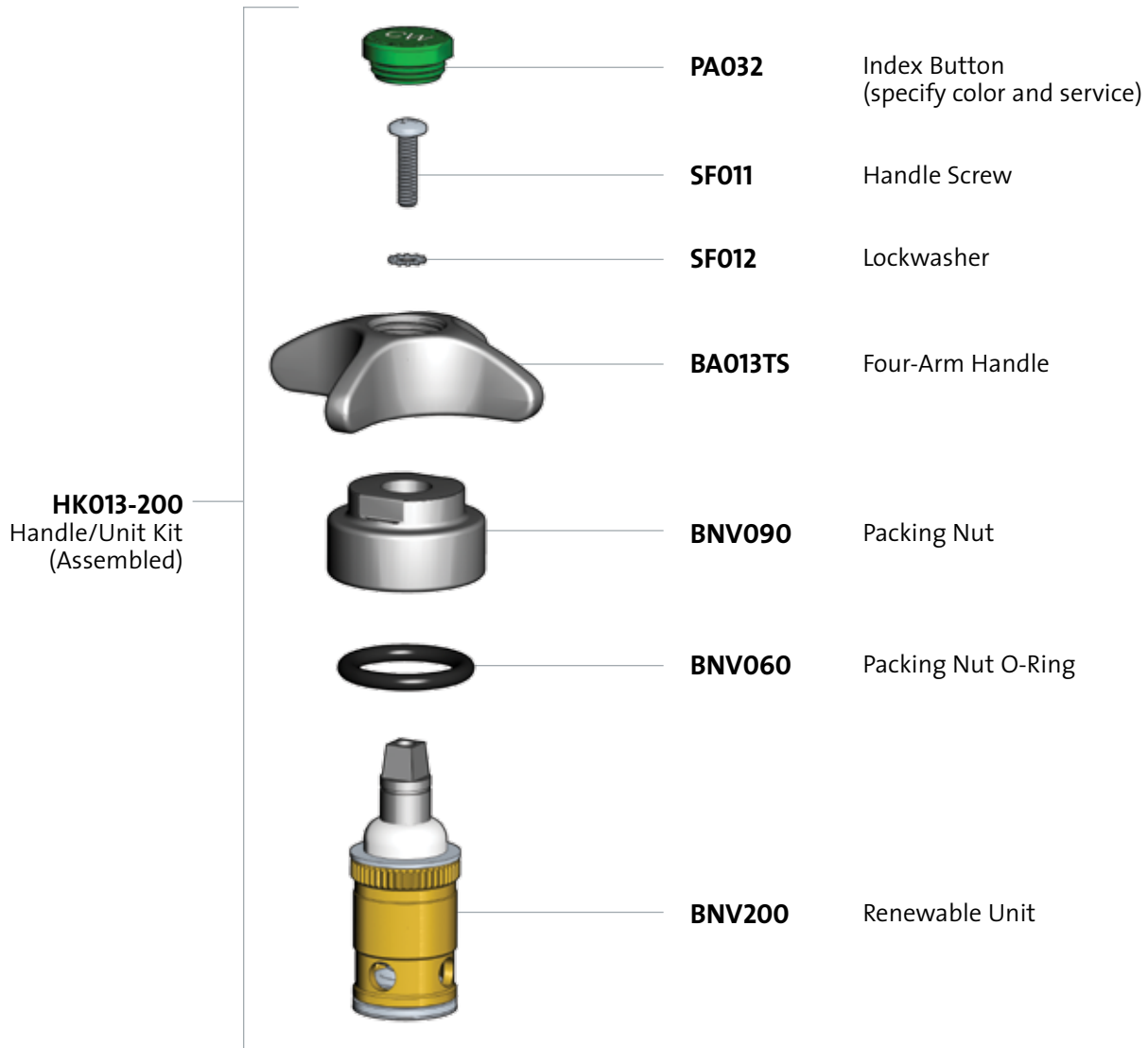

Notes:

1. Specify color and service for index button when ordering.
2. If tin lining for distilled, deionized or purified water is required, add suffix "TL".
3. If vandal-resistant packing nut with set screw is required, add suffix "VR".

○ **HK013-200AC** Handle/Unit Kit with BA013TS Four Arm Handle and BNV200AC Renewable Unit

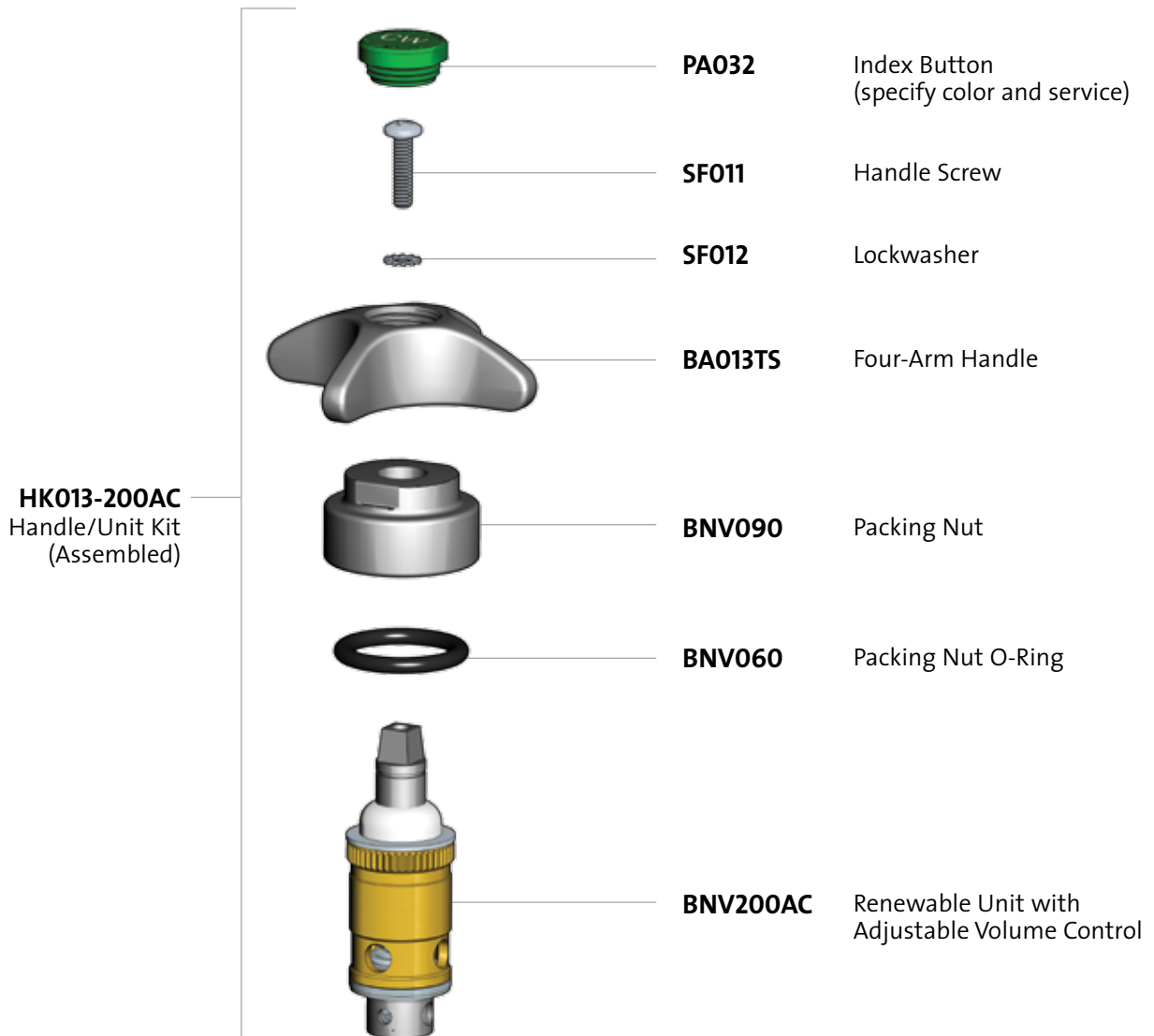

Notes:

1. Specify color and service for index button when ordering.
2. If tin lining for distilled, deionized or purified water is required, add suffix "TL".
3. If vandal-resistant packing nut with set screw is required, add suffix "VR".



- **HK044-200-90** Handle/Unit Kit with BA044TS Wrist Blade Handle and BNV200-90 Renewable Unit, Right Hand Thread
- **HK044-200LH-90** Handle/Unit Kit with BA044TS Wrist Blade Handle and BNV200LH-90 Renewable Unit, Left Hand Thread

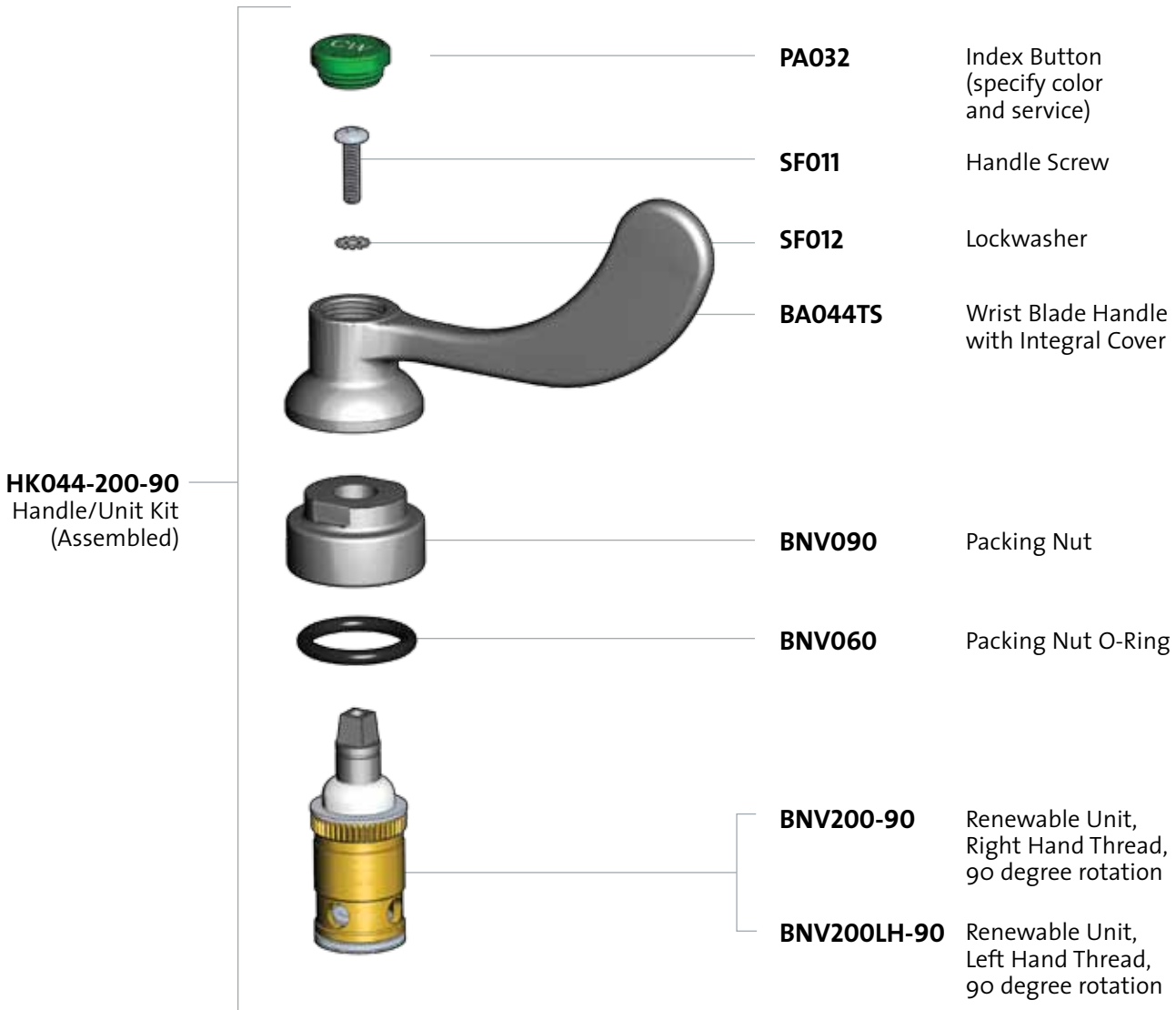

Notes:

1. Specify color and service for index button when ordering.
2. If tin lining for distilled, deionized or purified water is required, add suffix "TL".
3. If vandal-resistant packing nut with set screw is required, add suffix "VR".

- **HK044-200AC-90** Handle/Unit Kit with BA044TS Wrist Blade Handle and BNV200AC-90 Renewable Unit, Right Hand Thread
- **HK044-200AC-LH-90** Handle/Unit Kit with BA044TS Wrist Blade Handle and BNV200AC-LH-90 Renewable Unit, Left Hand Thread

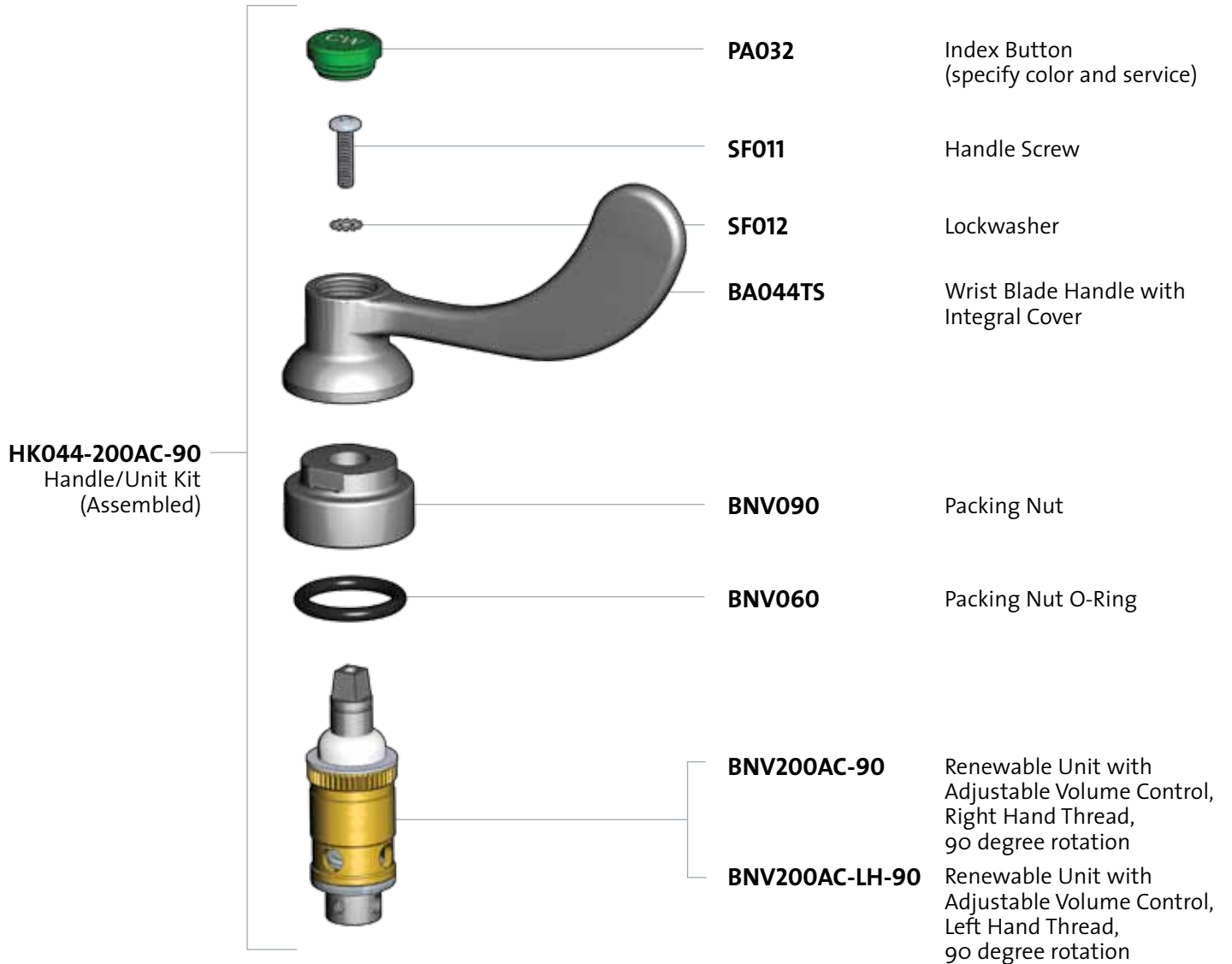

Notes:

1. Specify color and service for index button when ordering.
2. If tin lining for distilled, deionized or purified water is required, add suffix "TL".
3. If vandal-resistant packing nut with set screw is required, add suffix "VR".



- **BSC135** Renewable Unit, Self-Closing Control
- **BSC135LE** Same as above except with BA030 Self-Closing Lever Handle

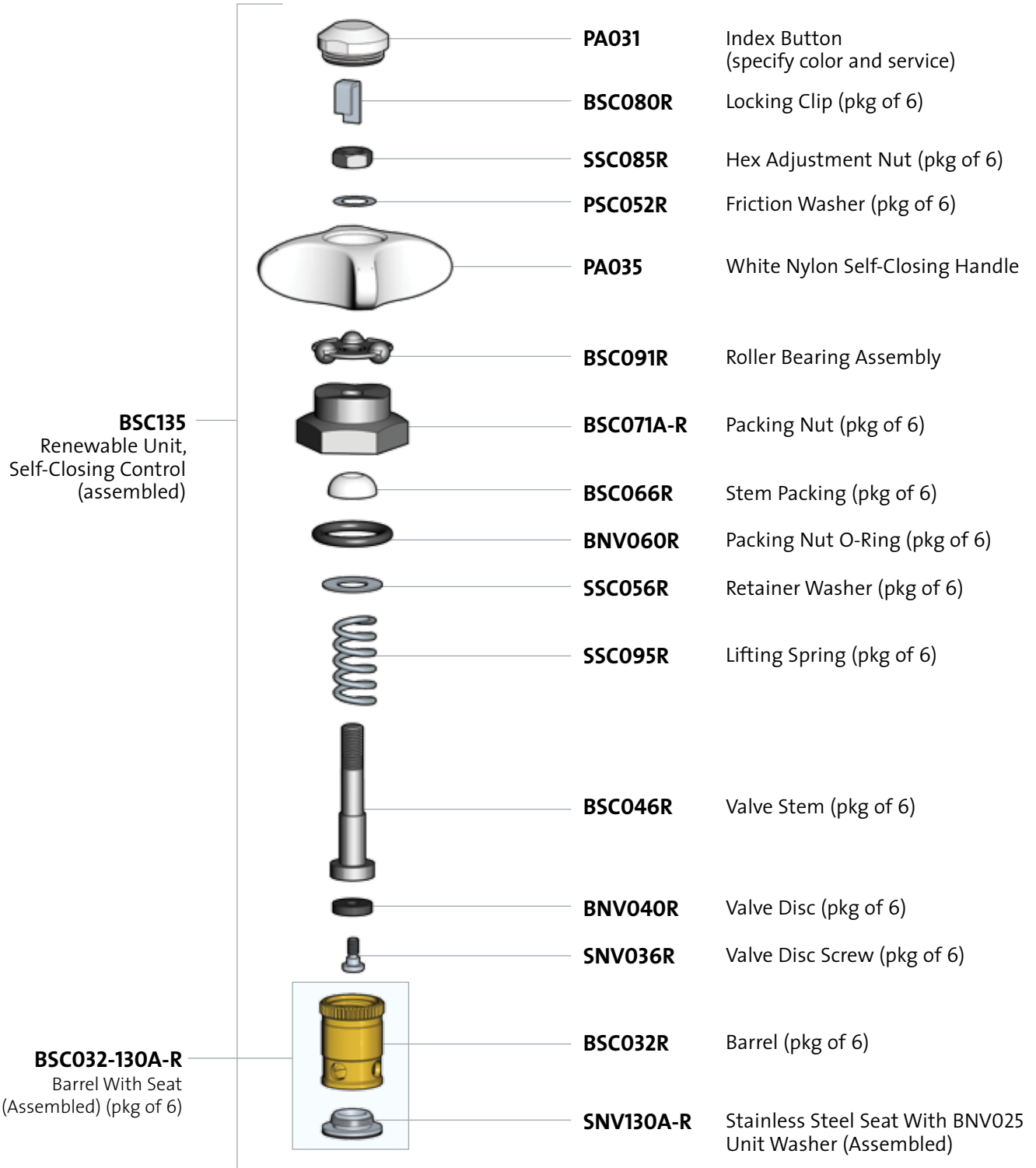

Note: If tin lining for distilled, deionized or purified water is required, add suffix "TL".

- **BSC135AC** Renewable Unit, Self-Closing Control, Adjustable Volume Control
- **BSC135AC-LE** Same as above except with BA030 Self-Closing Lever Handle

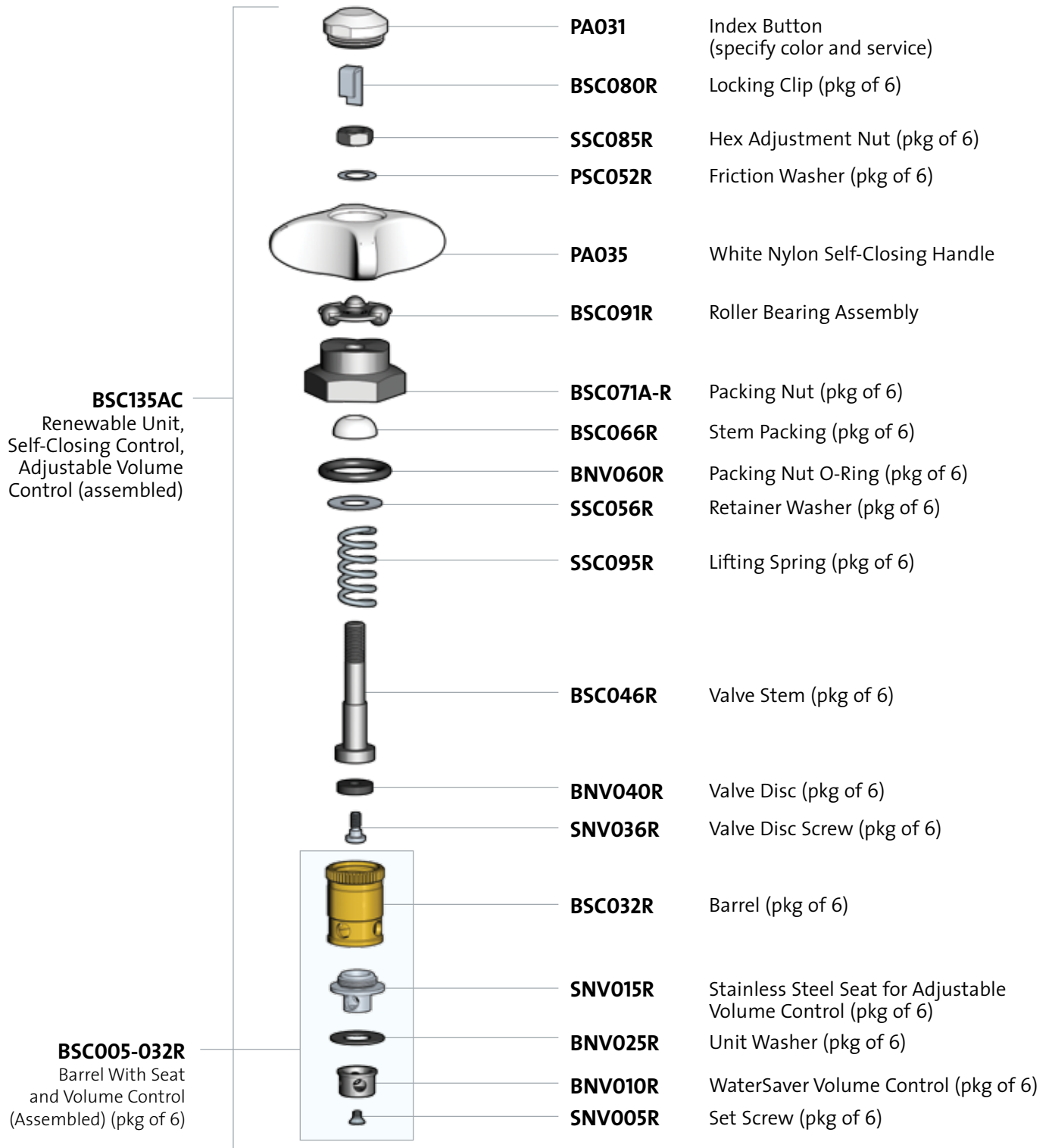

Note: If tin lining for distilled, deionized or purified water is required, add suffix "TL".



○ BSC011 / 016 / 021 Renewable Units for Foot-Operated Valves

WaterSaver foot-operated valves were redesigned as of April 1, 1995. Some of the new individual valve components (such as the valve stem and bonnet) are not interchangeable with the old components. Therefore, components for foot-operated valves are sold as complete units only.

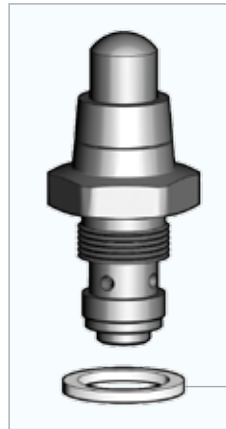

BSC011 Renewable Unit for L3001 / 3050 Foot-Operated Valves

PSC130R Unit Gasket (pkg of 6)

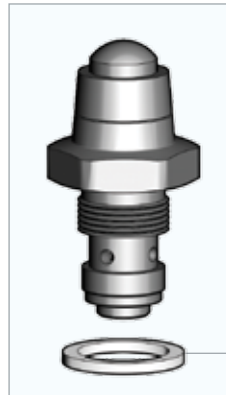

BSC016 Renewable Unit For L3010 / 3060 Foot-Operated Valves

PSC130R Unit Gasket (pkg of 6)

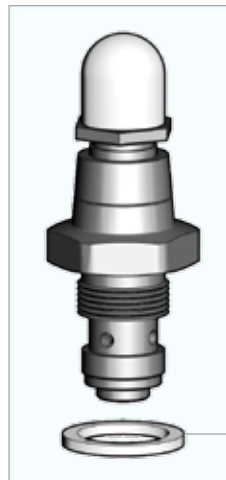

BSC021 Renewable Unit for L3001LP / 3050LP Foot-Operated Valves

PSC130R Unit Gasket (pkg of 6)

Notes:

1. If tin lining for distilled, deionized or purified water is required, add suffix "TL".
2. If extra heavy (5/32" thick) unit gasket is required, order PSC130A-R (pkg of 6).

- **PV100** Renewable Unit, Compression Control, PVC Construction
- **PV100PP** Renewable Unit, Compression Control, Polypropylene Construction
- **PV100CPVC** Renewable Unit, Compression Control, CPVC Construction

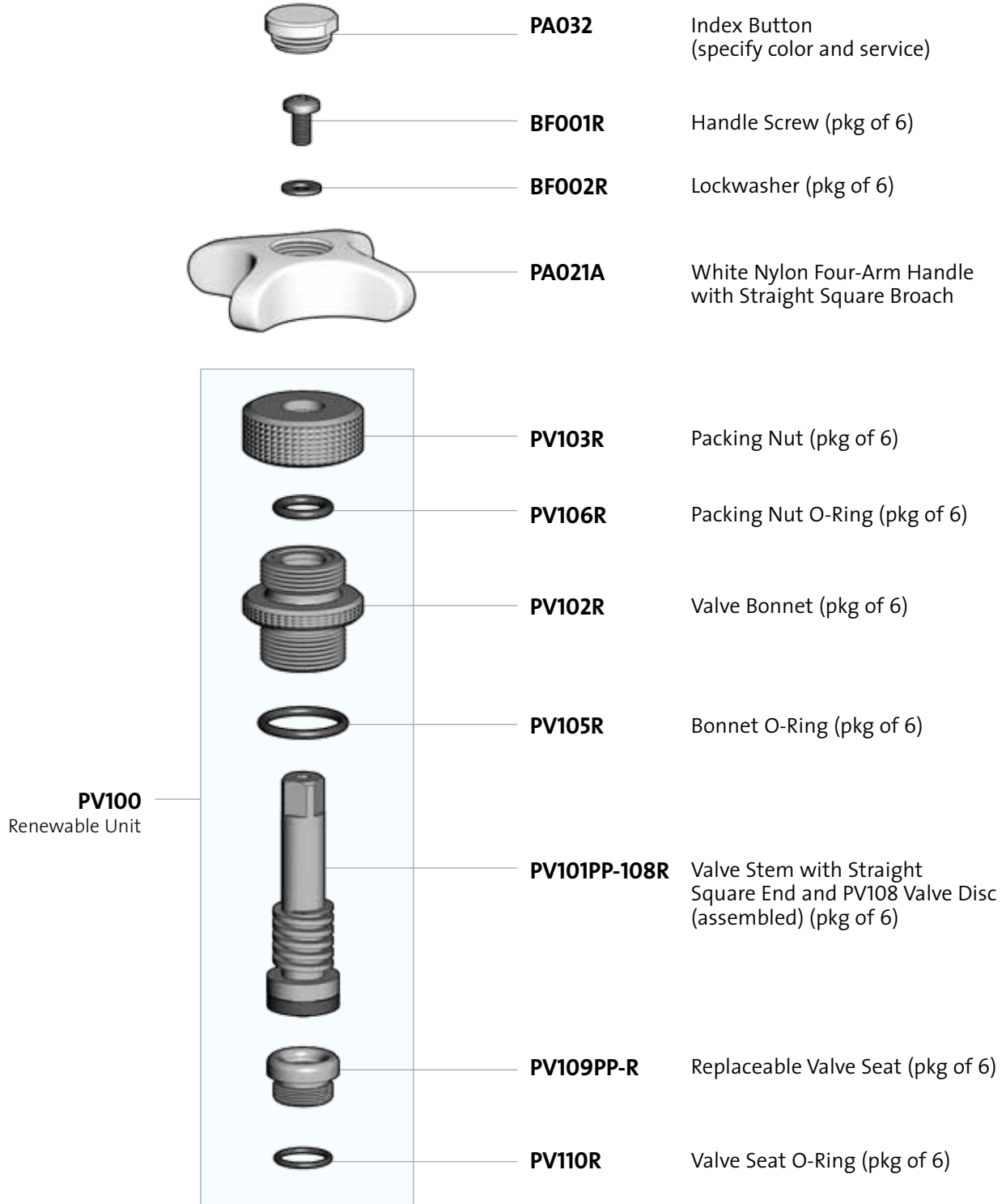

Note: When ordering components individually, specify material required (PVC, polypropylene or CPVC).

○ **HK019-7800** Handle/Unit Kit for Polypropylene- or PVDF- Lined Pure Water Fixtures, Compression Control (Old Style)

Note: This handle/unit kit is for use in L7833/7834/7837/7838/7840/7844 polypropylene- or PVDF- lined pure water fixtures. These fixtures were redesigned in 2002. Fixtures manufactured prior to 2002 utilize a valve body with a female thread (as shown). Fixtures manufactured after 2002 utilize a valve body with a male thread. This HK019-7800 handle/unit kit is for fixtures manufactured prior to 2002.

HK019-7800

Handle/Unit Kit, Polypropylene-Lined Pure Water Fixtures, Compression Control (Old Style)

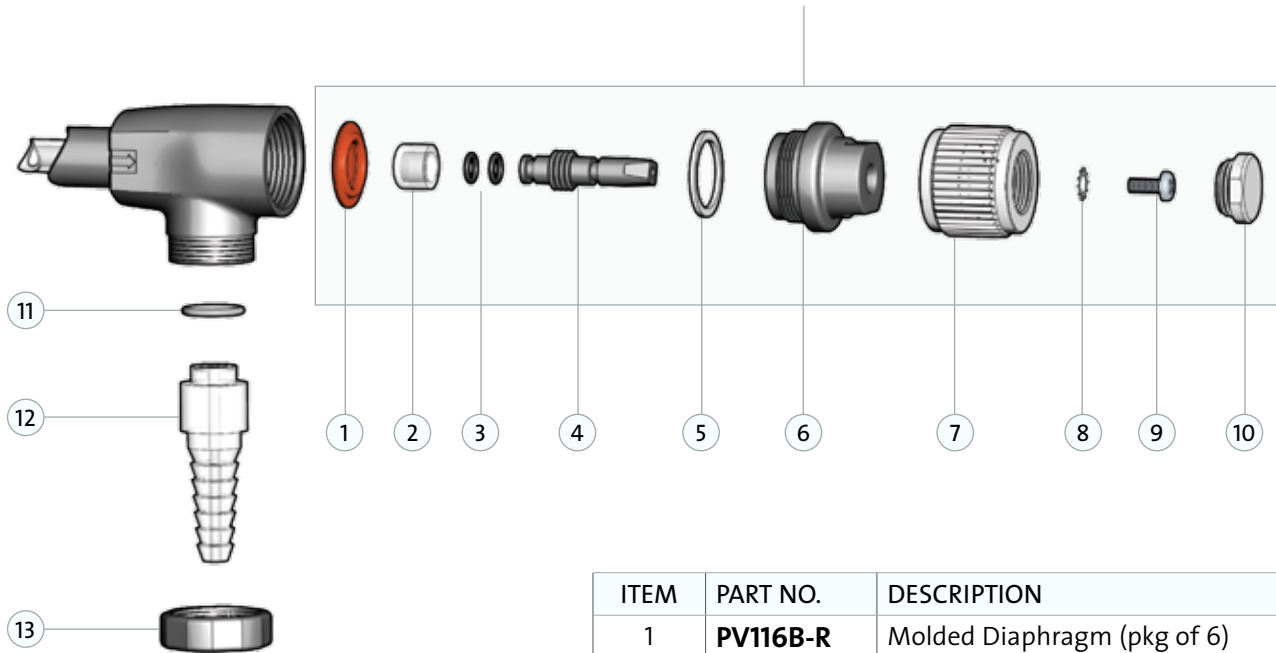

ITEM	PART NO.	DESCRIPTION
1	PV116B-R	Molded Diaphragm (pkg of 6)
2	PV120A-R	Valve Stem Cap (pkg of 6)
3	600-228R	O-Ring (2 required) (pkg of 12)
4	BV112B-R	Valve Stem (pkg of 6)
5	PV147R	Bonnet Gasket (pkg of 6)
6	BV107D-R	Valve Bonnet with Male Thread (pkg of 6)
7	PA019WHT	White Nylon Round Handle
8	SF012R	Lockwasher (pkg of 6)
9	SNV035R	Handle Screw (pkg of 6)
10	PA032	Index Button (specify color and service)
11	PO119R	Hose End O-Ring (pkg of 6)
12	PO118R	Hose End (pkg of 6)
13	BO108R	Outlet Nut (pkg of 6)

Note: RK7800R repair kit includes:
 (6) PV116B diaphragms
 (6) PV120A valve stem caps
 (12) 600-228 O-rings
 (6) PV147 bonnet gaskets

○ **HK019-7800A** Handle/Unit Kit for Polypropylene- or PVDF- Lined Pure Water Fixtures, Compression Control (New Style)

Note: This handle/unit kit is for use in L7833/7834/7837/7838/7840/7844 polypropylene- or PVDF- lined pure water fixtures. These fixtures were redesigned in 2002. Fixtures manufactured prior to 2002 utilize a valve body with a female thread. Fixtures manufactured after 2002 utilize a valve body with a male thread (as shown). This HK019-7800A handle/unit kit is for fixtures manufactured after 2002.

HK019-7800A

Handle/Unit Kit, Polypropylene-Lined Pure Water Fixtures, Compression Control (New Style)

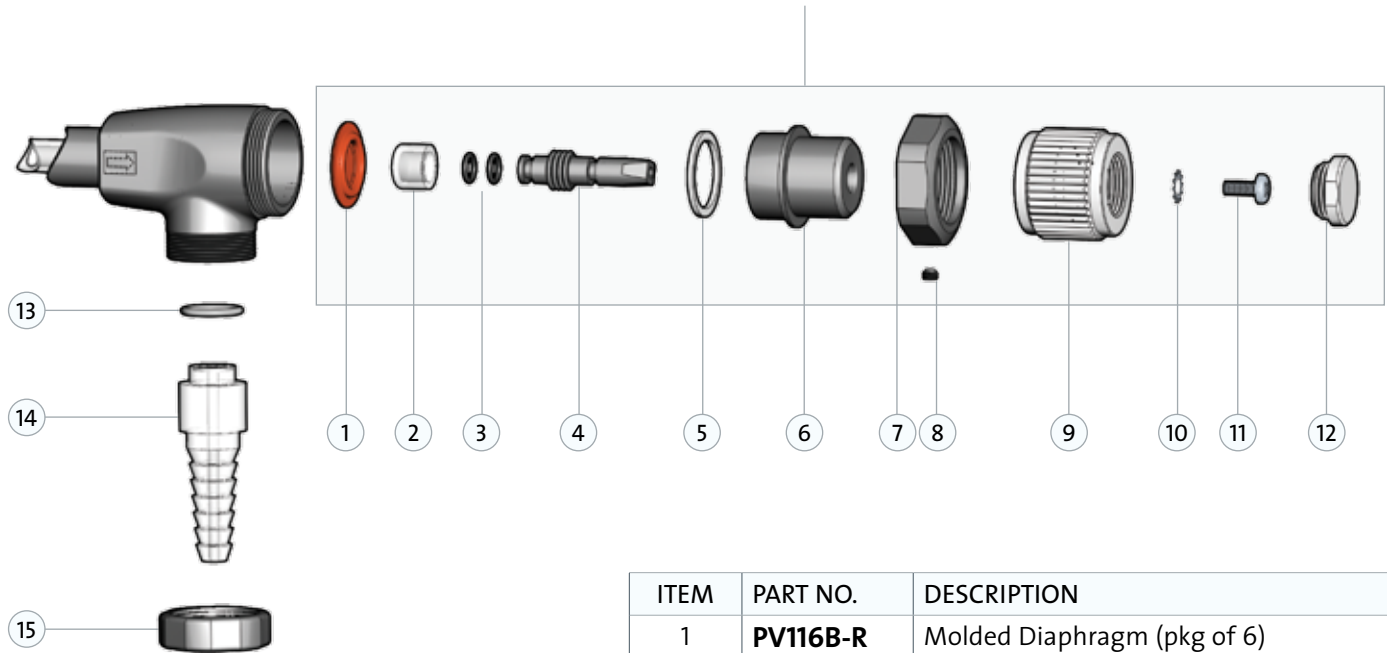

ITEM	PART NO.	DESCRIPTION
1	PV116B-R	Molded Diaphragm (pkg of 6)
2	PV120A-R	Valve Stem Cap (pkg of 6)
3	600-228R	O-Ring (2 required) (pkg of 12)
4	BV112B-R	Valve Stem (pkg of 6)
5	PV147R	Bonnet Gasket (pkg of 6)
6	BV146R	Valve Bonnet (pkg of 6)
7	BV148A-R	Retainer Nut (pkg of 6)
8	SF004R	Set Screw (pkg of 6)
9	PA019WHT	White Nylon Round Handle
10	SF012R	Lockwasher (pkg of 6)
11	SNV035R	Handle Screw (pkg of 6)
12	PA032	Index Button (specify color and service)
13	PO119R	Hose End O-Ring (pkg of 6)
14	PO118R	Hose End (pkg of 6)
15	BO108R	Outlet Nut (pkg of 6)

Note: RK7800R repair kit includes:
 (6) PV116B diaphragms
 (6) PV120A valve stem caps
 (12) 600-228 O-rings
 (6) PV147 bonnet gaskets



○ HK019-7850 Handle/Unit Kit for Polypropylene- or PVDF- Lined Pure Water Fixtures, Compression Control

Note: This handle/unit kit is for use in L7853/7854 polypropylene- or PVDF- lined pure water fixtures.



HK019-7850
Handle/Unit Kit, Polypropylene-Lined Pure
Water Fixtures, Compression Control

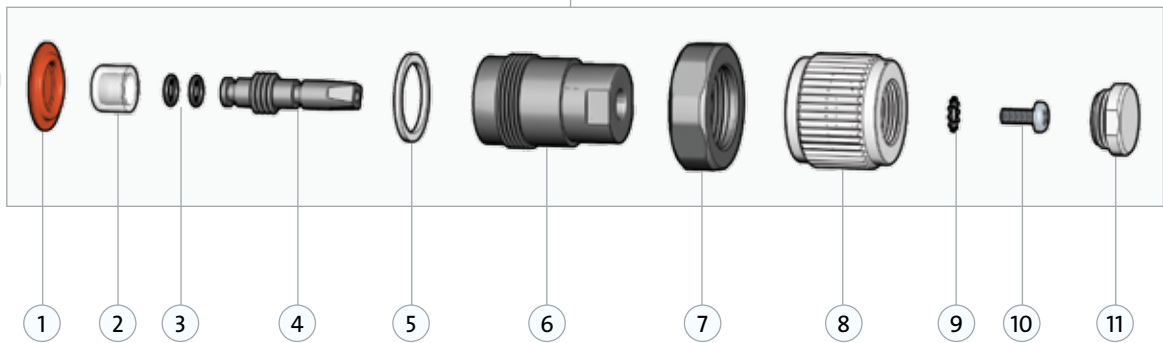

ITEM	PART NO.	DESCRIPTION
1	PV116B-R	Molded Diaphragm (pkg of 6)
2	PV120A-R	Valve Stem Cap (pkg of 6)
3	600-228R	O-Ring (2 required) (pkg of 12)
4	BV112D-R	Valve Stem (pkg of 6)
5	PV147R	Bonnet Gasket (pkg of 6)
6	BV142R	Barrel (pkg of 6)
7	B0391R	Retainer Nut (pkg of 6)
8	PA019WHT	White Nylon Round Handle
9	SF012R	Lockwasher (pkg of 6)
10	SNV035R	Handle Screw (pkg of 6)
11	PA032	Index Button (specify color and service)

Note: RK7800R repair kit includes:
(6) PV116B diaphragms
(6) PV120A valve stem caps
(12) 600-228 O-rings
(6) PV147 bonnet gaskets

- **HK035-7850SC** Handle/Unit Kit for Polypropylene- or PVDF- Lined Pure Water Fixtures, Self-Closing Control
- **HK030-7850SC** Same as above except with BA030 Self-Closing Lever Handle

Note: This handle/unit kit is for use in L7853SC/7853SC-LE/7854SC/7854SC-LE polypropylene- or PVDF- lined pure water fixtures.

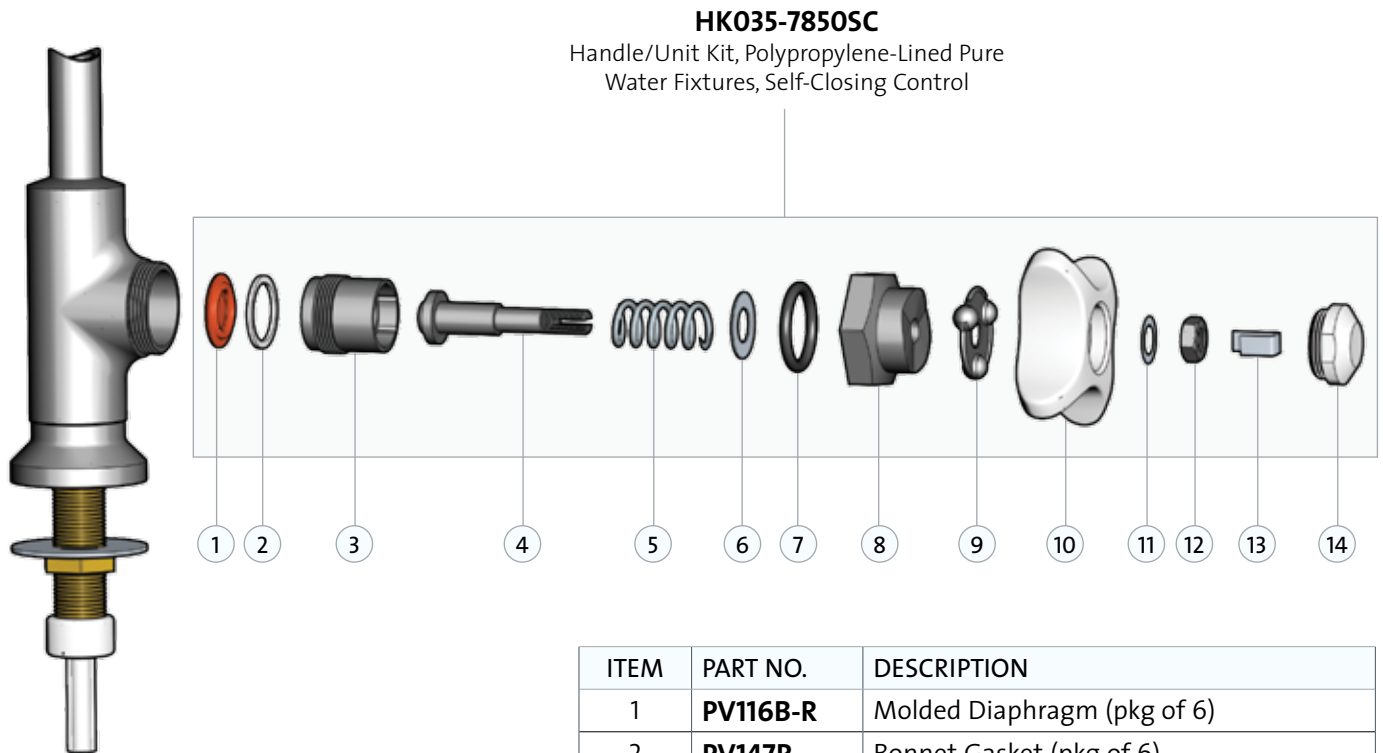

ITEM	PART NO.	DESCRIPTION
1	PV116B-R	Molded Diaphragm (pkg of 6)
2	PV147R	Bonnet Gasket (pkg of 6)
3	BV118SC-R	Self-Closing Barrel (pkg of 6)
4	BV112C-R	Self-Closing Valve Stem (pkg of 6)
5	SSC095R	Lifting Spring (pkg of 6)
6	SSC056R	Retainer Washer (pkg of 6)
7	BNV060R	Packing Nut O-Ring (pkg of 6)
8	BSC071A-R	Packing Nut (pkg of 6)
9	BSC091R	Roller Bearing Assembly (pkg of 6)
10	PA035	White Nylon Self-Closing Handle
11	PSC052R	Friction Washer (pkg of 6)
12	SSC085R	Hex Adjustment Nut (pkg of 6)
13	BSC080R	Locking Clip (pkg of 6)
14	PA031	Index Button (specify color and service)

○ **HK080C-7800SC** Handle/Unit Kit for Polypropylene- or PVDF- Lined Pure Water Fixtures, Self-Closing Control

Note: This handle/unit kit is for use in L7833SC/7834SC/7840SC polypropylene- or PVDF- lined pure water fixtures.

HK080C-7800SC

Handle/Unit Kit, Polypropylene-Lined Pure Water Fixtures, Self-Closing Control

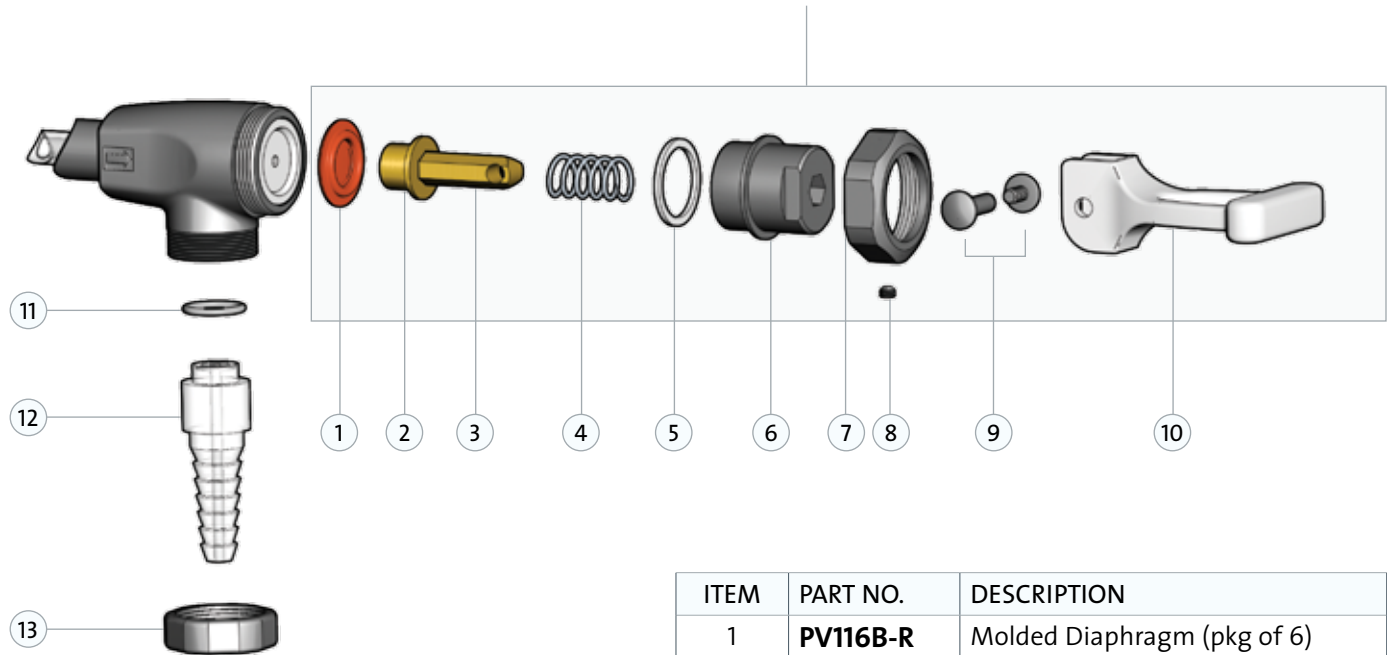

ITEM	PART NO.	DESCRIPTION
1	PV116B-R	Molded Diaphragm (pkg of 6)
2	BV144R	Brass Stem Cap (pkg of 6)
3	BV143R	Self-Closing Valve Stem (pkg of 6)
4	SV086R	Spring (pkg of 6)
5	PV147R	Bonnet Gasket (pkg of 6)
6	BV145R	Valve Bonnet (pkg of 6)
7	BV148A-R	Retainer Nut (pkg of 6)
8	SF004R	Set Screw (pkg of 6)
9	BV082A-R	Screw and Post (pkg of 6)
10	PA080C	White Nylon Self-Closing Handle
11	PO119R	Hose End O-Ring (pkg of 6)
12	PO118R	Hose End (pkg of 6)
13	BO108R	Outlet Nut (pkg of 6)

- **HK080B-7800MSC** Handle/Unit Kit for Polypropylene- or PVDF- Lined Pure Water Fixtures, Manual/Self-Closing Control

Note: This handle/unit kit is for use in L7833MSC/7834MSC/7840MSC polypropylene- or PVDF- lined pure water fixtures.

HK080B-7800MSC

Handle/Unit Kit, Polypropylene-Lined Pure Water Fixtures, Manual/Self-Closing Control

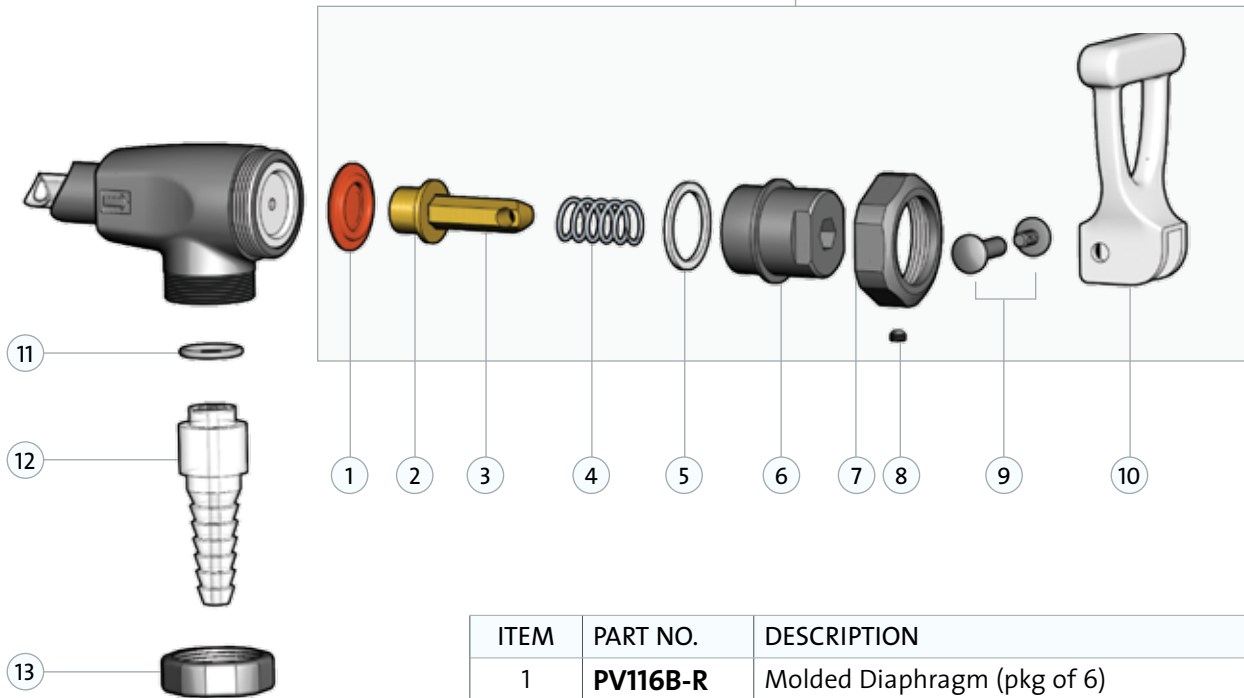

ITEM	PART NO.	DESCRIPTION
1	PV116B-R	Molded Diaphragm (pkg of 6)
2	BV144R	Brass Stem Cap (pkg of 6)
3	BV143R	Self-Closing Valve Stem (pkg of 6)
4	SV086R	Spring (pkg of 6)
5	PV147R	Bonnet Gasket (pkg of 6)
6	BV145R	Valve Bonnet (pkg of 6)
7	BV148A-R	Retainer Nut (pkg of 6)
8	SF004R	Set Screw (pkg of 6)
9	BV082A-R	Screw and Post (pkg of 6)
10	PA080B	White Nylon Manual/Self-Closing Handle
11	PO119R	Hose End O-Ring (pkg of 6)
12	PO118R	Hose End (pkg of 6)
13	BO108R	Outlet Nut (pkg of 6)

Swing Gooseneck Components



SWING GOOSENECK



BO070R Packing Nut with 1"-22 Male Thread (pkg of 6)



BO071R Friction Ring (pkg of 6)



BO075R Swing Gooseneck Packing (pkg of 6)



BO081R Split Retaining Ring (pkg of 6)



BO226R Swing Gooseneck Adaptor (3/8" Male NPT Inlet, 1"-22 Female Outlet) (pkg of 6)

Rigid/Swing Gooseneck Components



RIGID GOOSENECK



BO352A-R Retainer Nut (pkg of 6)



PO349R Nylon Washer (pkg of 6)



BO351R Double O-Ring Guide (pkg of 6)



BO353R O-Rings (2 required) (pkg of 12)



PO355R Nylon Spacer (Swing) (pkg of 6)



BO355R Brass Spacer (Rigid) (pkg of 6)



BO356R Rigid/Swing Adaptor (3/8" NPT Male Inlet, 1"-22 Male Outlet) (pkg of 6)

BO356COMP Rigid/Swing Adaptor with Gooseneck Components (PO349 through BO355)



BO350R Rigid/Swing Adaptor (1"-22 Male Thread) (pkg of 6)



BO354R Copper Body Gasket

Notes:

1. To convert a faucet with a rigid gooseneck to swing using swing construction, order BO226 adaptor and SG series swing gooseneck.
2. To convert a faucet with a rigid gooseneck to swing using rigid/swing construction, order BO356COMP (BO356 and parts PO349 through BO355).

○ **L100 / 101 / 102 / 112** Atmospheric Vacuum Breakers

WaterSaver atmospheric vacuum breakers were redesigned in 2004. Vacuum breakers manufactured prior to 2004 utilize a float cup with a cone-shaped bottom. Vacuum breakers manufactured after 2004 utilize a float cup with a cylinder-shaped flat bottom (shown below). The new float cup incorporates a small sealed air pocket that gives the float cup increased buoyancy and reduces spillage at low flow.

Internal components for the new style construction can be used in faucets manufactured prior to 2004. However, in such older faucets, the new components might reduce the water flow through the vacuum breaker. If this occurs, it might be necessary to install the old style components in the vacuum breaker (order "RK100R-OS"). Please consult with the WaterSaver factory for further assistance.

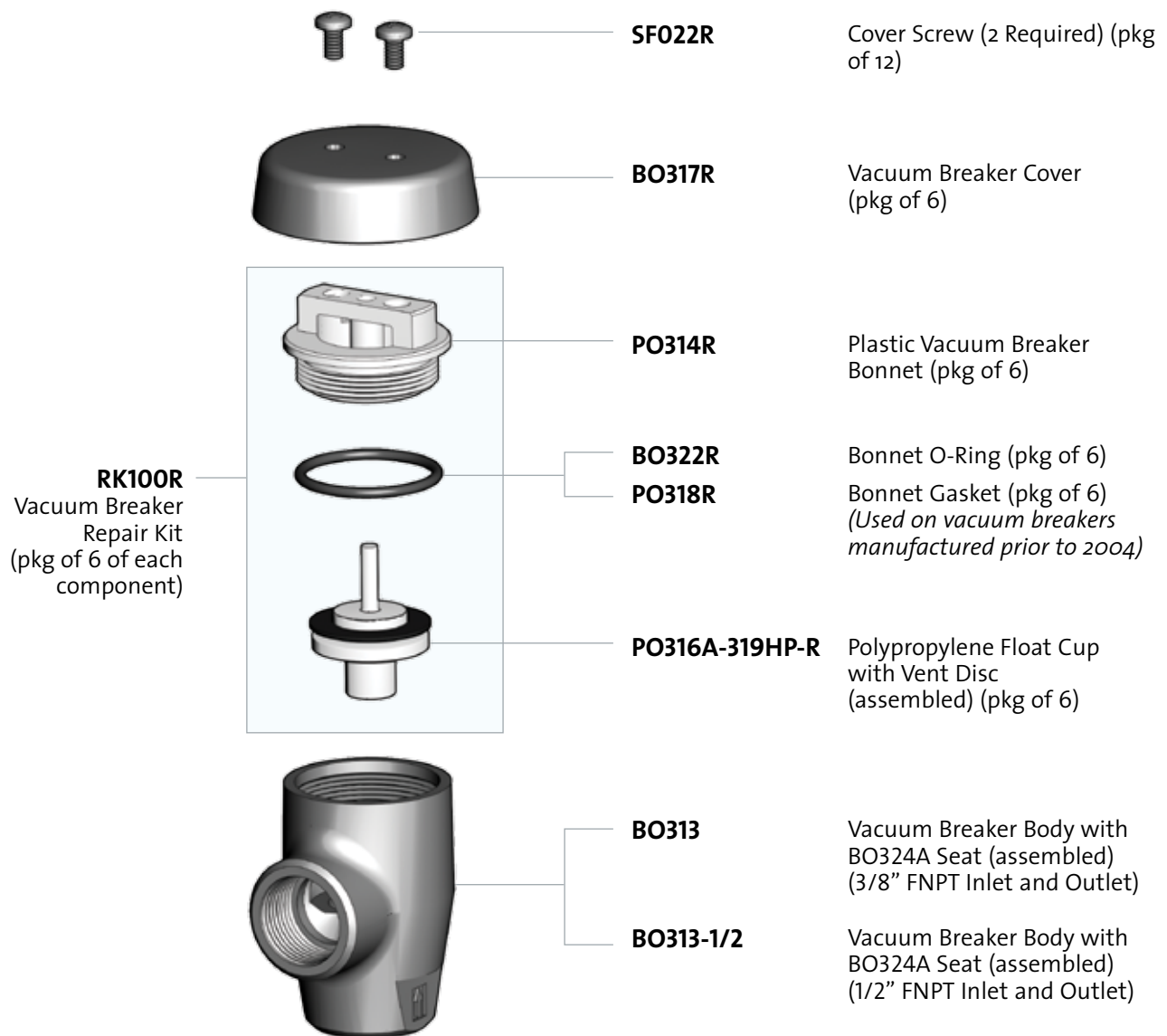

○ **L100VR** Atmospheric Vacuum Breaker For Vandal-Resistant Faucets

WaterSaver atmospheric vacuum breakers were redesigned in 2004. Vacuum breakers manufactured prior to 2004 utilize a float cup with a cone-shaped bottom. Vacuum breakers manufactured after 2004 utilize a float cup with a cylinder-shaped flat bottom (shown below). The new float cup incorporates a small sealed air pocket that gives the float cup increased buoyancy and reduces spillage at low flow.

Internal components for the new style construction can be used in faucets manufactured prior to 2004. However, in such older faucets, the new components might reduce the water flow through the vacuum breaker. If this occurs, it might be necessary to install the old style components in the vacuum breaker (order "RK100R-OS"). Please consult with the WaterSaver factory for further assistance.

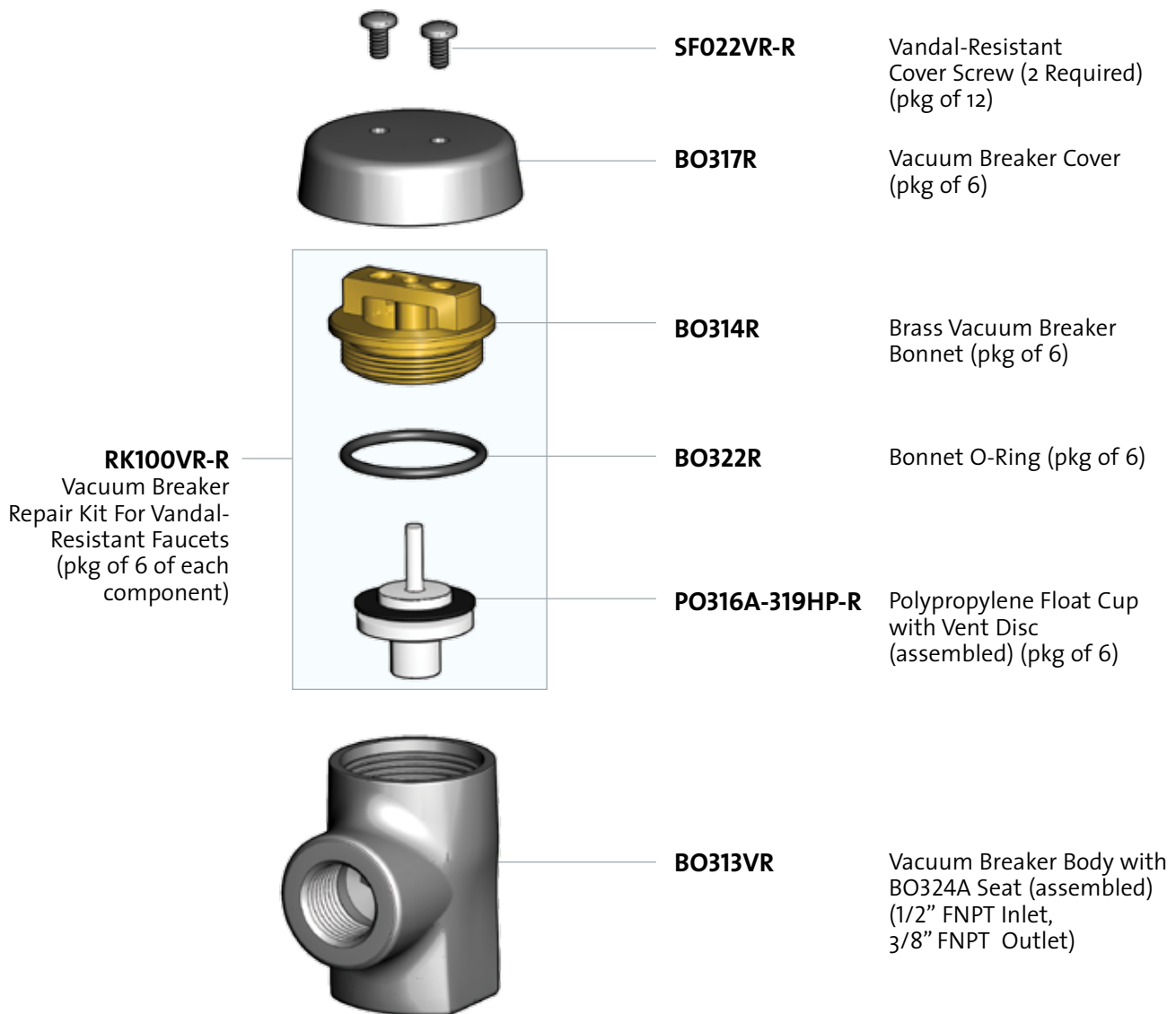

○ L100/101/102/112 Atmospheric Vacuum Breakers

Maximum Pressure: 125 PSI

Maximum Temperature: 180°F

ASSE Certified under ASSE Standard 1001

Atmospheric vacuum breakers are used to prevent back-siphonage of contaminated water into a potable water system. They are not designed to protect against backpressure conditions; protection against backpressure may require installation of a backflow preventer in the water supply line.

WaterSaver vacuum breakers are intended for use on laboratory faucets and valves. They are typically installed as an integral part of a laboratory faucet gooseneck. In addition, they are used in water supply systems installed in fume hoods, mounted between a remote control water valve and an outlet fitting. As such, WaterSaver vacuum breakers are designed and constructed specifically for the requirements of laboratory applications. They are designed to seal properly and prevent spillage at as low a flow as possible, thus facilitating many common laboratory procedures. However, under certain circumstances, spillage of water from under the vacuum breaker cover can occur.

The purpose of these guidelines is to assist in the correct installation, operation and maintenance of WaterSaver vacuum breakers. In addition, these guidelines will assist in troubleshooting in the event that spillage does occur.

IMPORTANT: Be sure to review applicable local plumbing codes prior to selecting or installing a vacuum breaker. Many codes have specific provisions regarding the type of vacuum breaker that may be used and the design of the system in which it is used.

Installation

The water supply line must be thoroughly flushed prior to installation. The presence of any scale, debris, chips, thread sealant, etc. in the water line may cause fouling of the vacuum breaker, prevent proper sealing of the float cup and damage internal components.

The vacuum breaker must be installed with the supply connected to the bottom inlet of the vacuum breaker.

An atmospheric vacuum breaker must be installed downstream of the last valve in the water supply line.

The Uniform Plumbing Code requires that “potable water outlets with hose attachments...shall be protected by... an atmospheric vacuum breaker installed at least six (6) inches above the highest point of usage and located on the discharge side of the last valve.” [Uniform Plumbing Code, Section 603.4.7 (2003)] Consequently, when the vacuum breaker is installed, the bottom of the vacuum breaker body must be at least 6” above the flood level rim of the sink or fixture into which water is discharged. [See Figure 1.] Where a hose is to be attached to a serrated hose end, the vacuum breaker must be installed at least 6” above the highest point to which the hose can be raised. [See Figure 1.]

Vacuum breakers must be installed in a plumb and level position, perpendicular to the finished floor. If a vacuum breaker is installed in a tilted or angled position, the float cup will tend not to seal squarely against the bottom of the vacuum breaker bonnet. This can promote leakage under low flow conditions.

Since atmospheric vacuum breakers require routine inspection and maintenance (primarily cleaning and/or replacement of internal components), they should be installed in locations in which they are readily accessible. In addition, the Uniform Plumbing Code prohibits installing a backflow preventer in any area containing toxic, poisonous or corrosive fumes. [Uniform Plumbing Code, Section 603.4.15 (2003)] Vacuum breakers should thus not be installed within the work space of a laboratory fume hood.

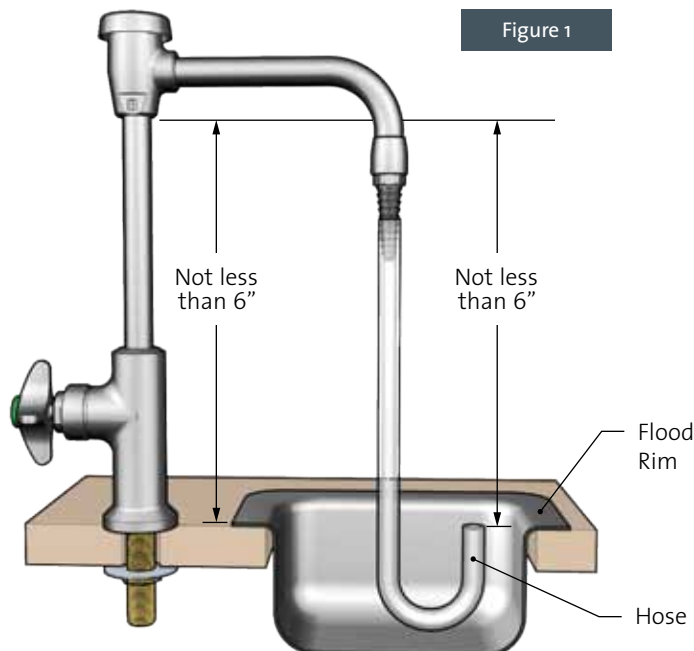

Operation

When the water control valve is closed, the vacuum breaker float cup rests on the vacuum breaker seat. [See Figure 2.] In this position, the atmospheric vent is open and the waterway through the seat is closed.

When the water valve is opened, the water flow pushes the float cup up off the seat and against the vacuum breaker bonnet. The float cup gasket seals against the bottom face of the bonnet. This seal prevents water from passing through the atmospheric vent and spilling out from underneath the vacuum breaker cover.

In the event of a loss of pressure on the upstream side of the vacuum breaker and the resulting creation of a negative pressure in the supply line, the float cup drops back down onto the seat. This opens the atmospheric vent and closes the waterway. This action admits air into the discharge line downstream of the vacuum breaker, thereby preventing the creation of a vacuum and stopping any back-siphonage.

An atmospheric vacuum breaker cannot be used in applications where it is subject to continuous water pressure. In addition, the water control valve should not be left open for extended periods of time.

Maintenance

Contamination of the internal components of the vacuum breaker (e.g. mineral deposits on the float cup gasket or bonnet) may cause a loss of the seal between the float cup gasket and bonnet. Therefore, vacuum breakers should be inspected periodically (at least monthly) for contamination and/or deterioration of the internal working components. Components should be cleaned or replaced as required.

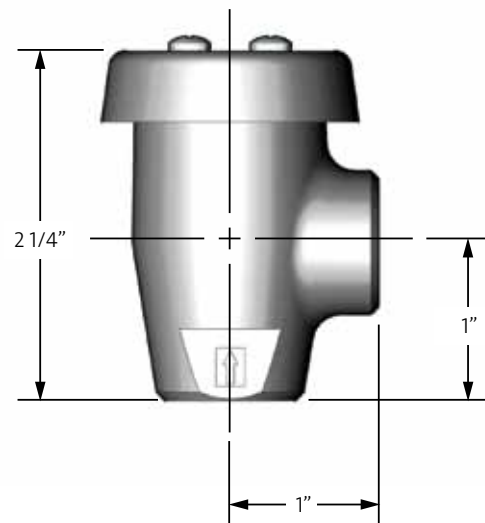
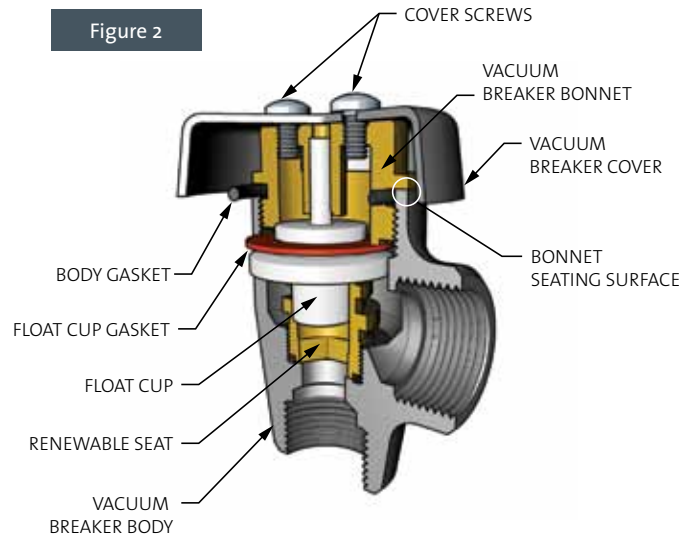

Troubleshooting

The most common problem associated with atmospheric vacuum breakers is the occurrence of spillage of water from underneath the vacuum breaker cover. There are many possible causes of this. Set forth below is a list of the potential causes of spillage, together with the appropriate solution for the problem:

1. **Vacuum Breaker Installed At Angle.** As noted above, if a vacuum breaker is installed in a tilted or angled position, the float cup will not seal evenly against the bottom of the bonnet. To address this issue, adjust the position of the vacuum breaker so as to be plumb and level.
2. **Contamination of Float Cup Gasket.** If the water contains a high level of calcium or other minerals, deposits and scale can accumulate on the float cup gasket. If this occurs, the gasket will not seal completely against the bonnet. The gasket should be cleaned or replaced.
3. **Contamination of Bonnet.** Build-up of deposits can occur on the seating surface of the bonnet as well. The bonnet must then be cleaned or replaced.
4. **High Water Pressure.** As noted above, WaterSaver vacuum breakers are designed specifically for laboratory applications. The float cup and gasket are extremely light to permit sealing at as low a flow as possible (since many laboratory procedures require low flow over an extended period of time). When used in water systems with high water pressure (greater than 70 PSI), these components can wear out more quickly than at low pressure. If that occurs, the vacuum breaker may not seal properly at low flow. In higher pressure applications, the float cup and gasket might require replacement at more frequent intervals.
5. **Deterioration of Bonnet Gasket.** The vacuum breaker bonnet is sealed into the vacuum breaker body using a nylon gasket or O-ring. Over time, this gasket or O-ring can deteriorate and leakage can occur. In that event, the gasket or O-ring should be replaced.
6. **Connection to Elevated Equipment.** As noted above, the vacuum breaker must be installed at least 6" above the flood level rim of the sink or the highest point which can be reached by a hose attached to the outlet. Thus, if a hose is attached to the serrated end of a laboratory faucet, the free end of the hose should not be capable of reaching a height that is less than 6" below the vacuum breaker.

Spillage can occur in the event that a hose is attached to a faucet and extended above the level of the vacuum breaker. In this situation, when the valve is opened and water is flowing through the system, there can be an accumulation of water in the hose downstream of the vacuum breaker. The pressure created by the weight of the downstream water may exceed the water pressure upstream of the vacuum breaker, causing a negative pressure situation. This will cause a reversal of flow, the vacuum breaker will close, and spillage will occur. In this situation, the vacuum breaker is acting exactly as it is designed in preventing backflow.

The situation described above is most likely to occur when the water control valve is opened a slight amount and left in this position for a long period of time. Fluctuations in supply line pressure and flow may cause the float cup to "flutter" rather than seal continuously against the bonnet. This will accentuate the tendency for a negative pressure situation to develop.

One possible solution for spillage of this type is to install a non-positive closing volume control device (such as the WaterSaver BO358) on the faucet outlet. The control valve can then be fully opened, permitting the vacuum breaker float cup to seal. Water flow is metered using the volume control on the outlet. As noted above, the Uniform Plumbing Code requires that vacuum breakers be located on the discharge side of the last valve in the water line. Therefore, the volume control device must not be capable of fully closing.

- **BV200N** Needle Valve Components
- **BV200N-PM** Needle Valve Components for Panel Mounted Fume Hood Valve

- **BV200FCN** Fine Control Needle Valve Components
- **BV200NFCN-PM** Fine Control Needle Valve Components for Panel Mounted Fume Hood Valve

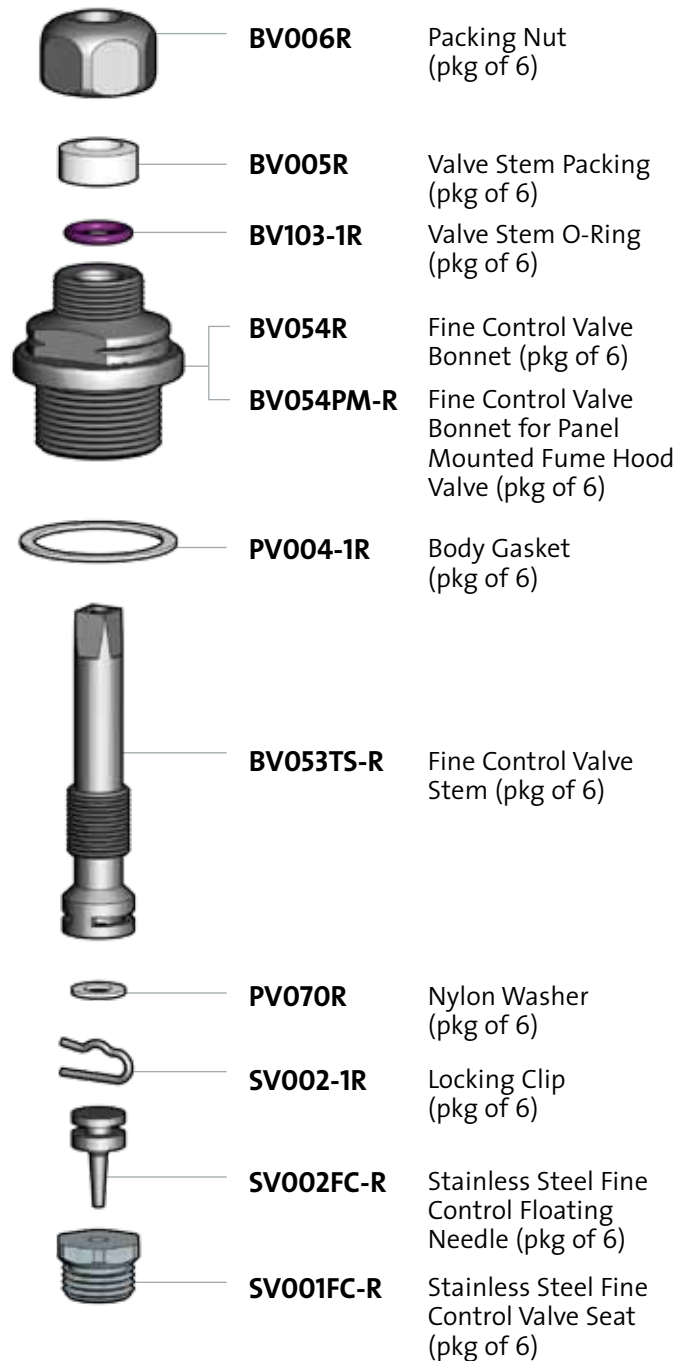
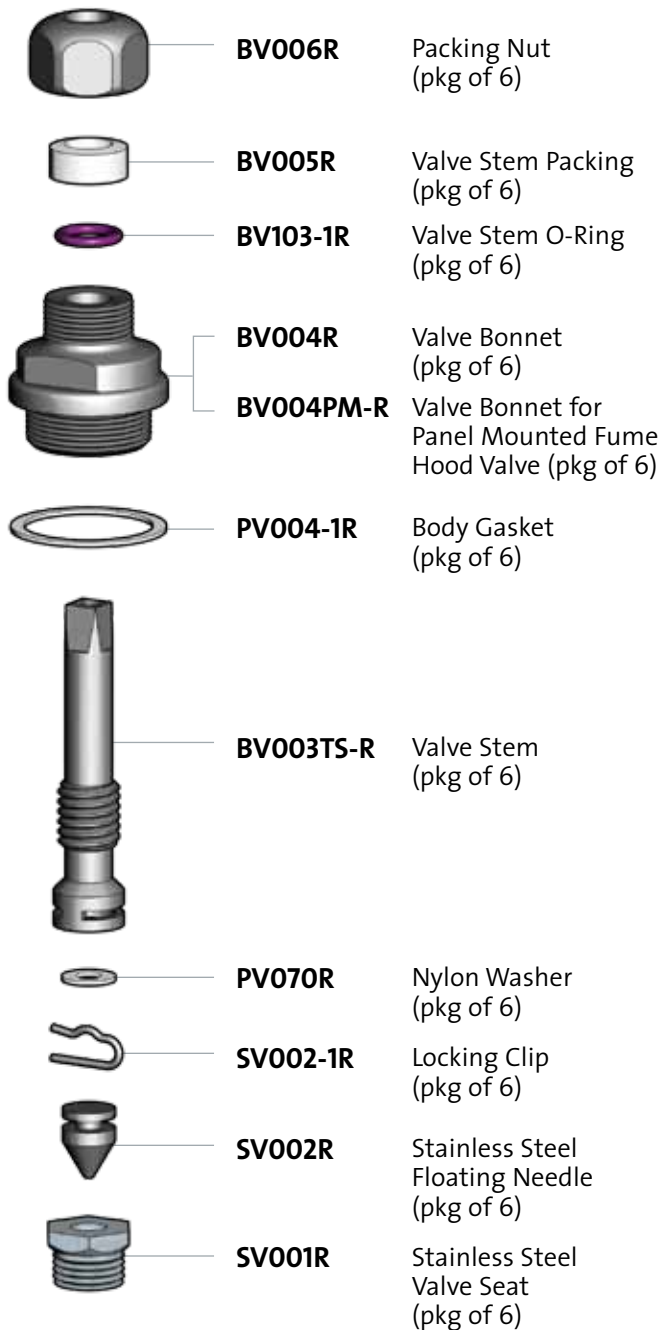

Note: If valve is used for oxygen or pure gas service, components must be specially cleaned, lubricated and packed.

- **BV200S** Steam Valve Components
- **BV200S-PM** Steam Valve Components for Panel Mounted Fume Hood Valve

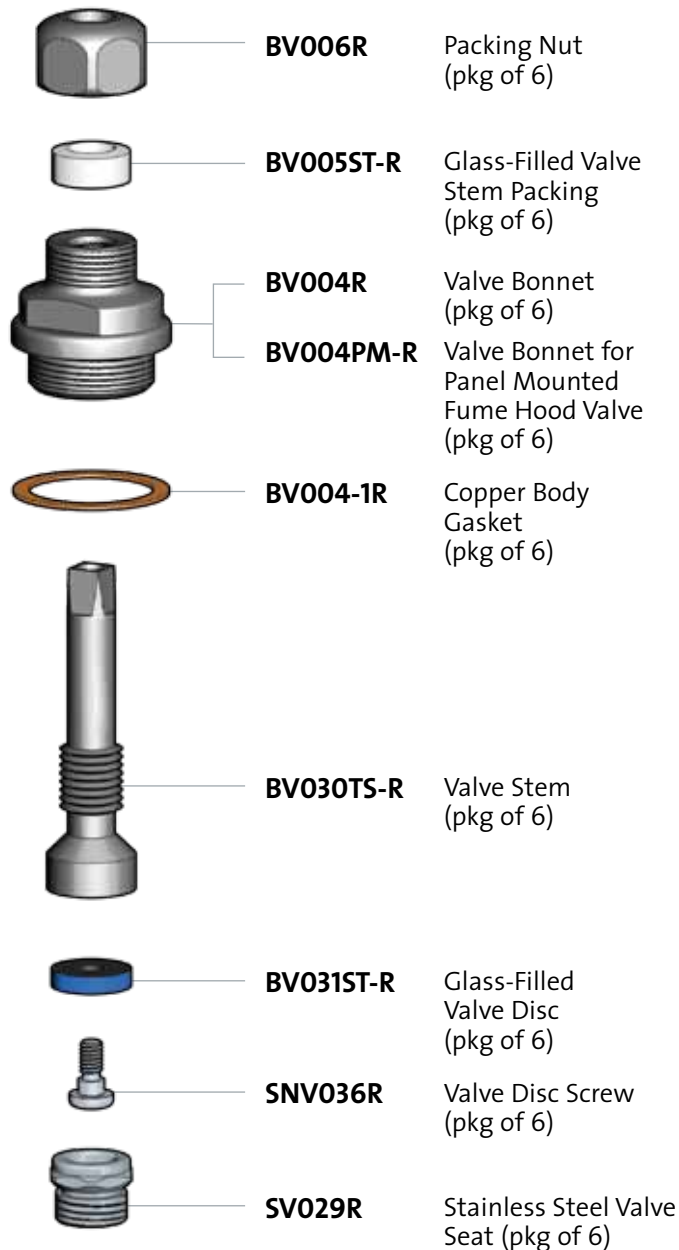

- **BV200W** Water Valve Components
- **BV200W-PM** Water Valve Components for Panel Mounted Fume Hood Valve

Note: BV200W is used on remote control water valves for fume hood use.

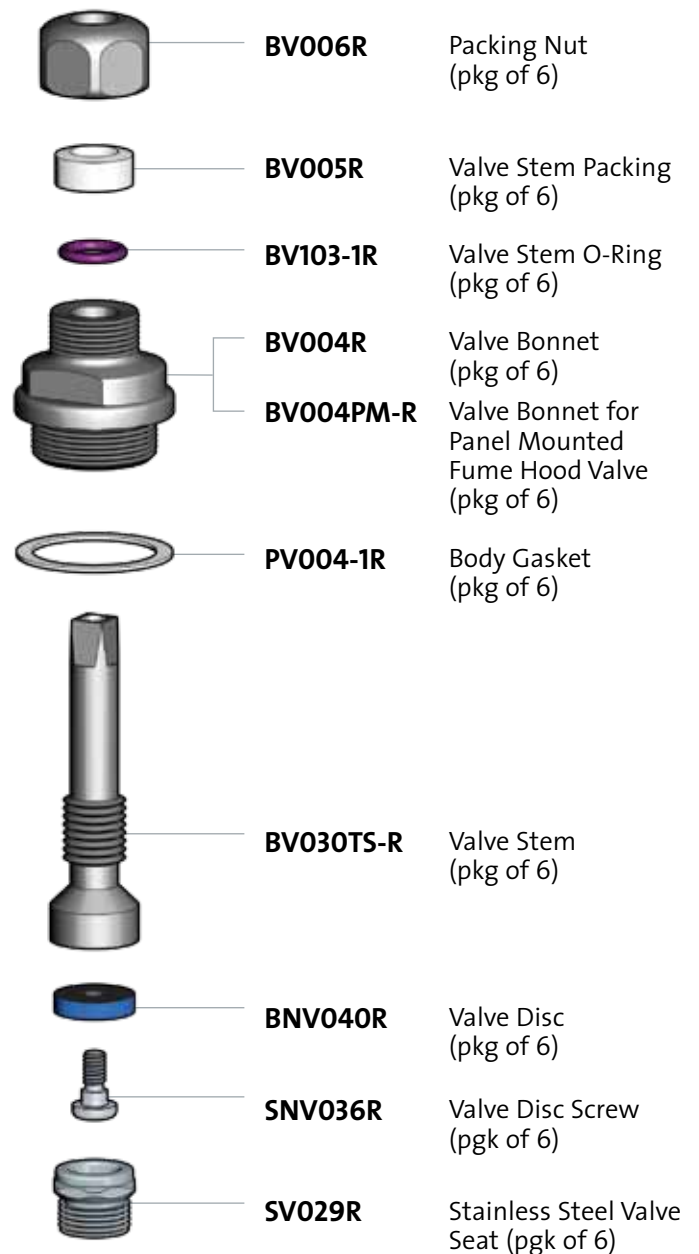



TEL AFA 500 TROUBLESHOOTING GUIDE



Problem	Check for...
No Lights	<ul style="list-style-type: none">❖ Power cord plugged securely into back of monitor❖ Power supply plugged into outlet❖ Correct voltage to outlet
Green light blinking	<ul style="list-style-type: none">❖ Unit may be in "permanent horn silence" mode. Press and hold ENTER and SET buttons for 10 seconds.❖ Unit may be in Night Setback mode. This mode is activated by sending an external signal into the relay input in the back of the monitor. Unit will return to normal operating mode (solid green light) when Night Setback mode is deactivated by external signal.
Both lights blinking, horn sounding	<ul style="list-style-type: none">❖ Unit is in calibration mode. To calibrate, move sash to a position that gives face velocity equal to the desired alarm point and perform single point calibration (press and hold ENTER and SET button together for five seconds to initiate air sampling).
Red light blinking	<ul style="list-style-type: none">❖ Unit is in alarm mode and horn is temporarily silenced. Lower the sash to generate greater face velocity, then raise sash. When the face velocity goes below the alarm point, you should then get a solid red light and the horn.❖ Unit may be in Night Setback mode. This mode is activated by sending an external signal into the relay input in the back of the monitor. Unit will return to normal operating mode (solid green light or solid red light and horn) when Night Setback mode is deactivated by external signal.
Unit will not take a calibration	<ul style="list-style-type: none">❖ Make sure fan is running and air is being exhausted through the hood.❖ Make sure hose is connected properly at the side wall and to the rear of the monitor. If disconnected, reconnect and calibrate again per the owner's manual.❖ Make sure you are following the directions in the owner's manual for the proper calibration. The AFA 500 has two methods of calibrating. Most units are shipped from the factory ready for the single-point calibration method.
For other issues	<ul style="list-style-type: none">❖ Call HSE, 847-680-9930, for customer service phone assistance.





TEL AFA 1000/1 TROUBLESHOOTING GUIDE



Problem	Check for...
No lights	<ul style="list-style-type: none"> ❖ Power cord plugged securely into back of monitor. ❖ Power supply plugged into outlet. ❖ Correct voltage to outlet.
Red light on or blinking, no alarm sound	<ul style="list-style-type: none"> ❖ Unit is in “permanent horn silence” mode. (Display should show picture of a horn crossed out). Horn may be re-enabled in Cal Configure menu.
Velocity displayed does not match anemometer	<ul style="list-style-type: none"> ❖ Air patterns in the room may have changed since last calibration. Re-calibrate per owner’s manual instructions.
Velocity displayed although fan is off	<ul style="list-style-type: none"> ❖ Make sure hose is connected properly at the side-wall and to the SM6 sensor or post opening. If disconnected, reconnect and re-calibrate. If needed, consider manually shortening length of air hose between sidewall hole and post opening. Alternatively, check for drafts in room.
Calibration tips 	<ul style="list-style-type: none"> ❖ Make sure fan is running and air is being exhausted through the hood. ❖ Make sure hose is connected properly at the sidewall and to the SM6 sensor or post opening. If disconnected, reconnect and calibrate again per the owner's manual. ❖ Use a thermoanemometer or vane anemometer to collect velocity readings. Take extra time (at least 15 to 20 seconds, more on larger hoods) to wait for the airflow to settle between capturing the low velocity reading (sash high) and the high velocity reading (sash low). This will minimize the chance for a calibration error due to excessive fluctuations. ❖ Be careful to avoid movement around the front of the hood while sensor is taking its air sample. ❖ High air value and low air value must be different by at least 60 fpm. This parameter can be adjusted in Cal Configure menu. ❖ Do not use fully open and fully closed as the two calibration points. Try using normal operating height for the low velocity sample and reducing the opening by half for the high velocity sample. With a bypass hood, the recommended positions are full open for the low velocity reading, and for the high velocity reading, open the sash to where the top just covers the bypass opening. ❖ Hoods already under VAV control require two different setups for a calibration: “normal” exhaust for the low reading and “purge” or max exhaust for the high reading. Suggested values to start with are 100 fpm and 300 fpm respectively.
Outside influences	If repeated attempts at calibration fail to yield acceptable results, try to determine if other airflow patterns or influences are present in or around the hood. Things to check include: <ul style="list-style-type: none"> • Air coming from a supply diffuser or grille in the ceiling near the hood. • Cross-currents or drafts. • Unusually high room pressure in the lab (make sure lab doors are in their normal position during calibration). • Abnormalities in room temperature or humidity (this might indicate a room that is not properly balanced). • Room heating or air conditioning may be cycling on and off during calibration. • If two or more hoods are ganged together on one exhaust fan, sash position of adjacent hoods may have an effect. • A large apparatus in the hood can affect face velocity.
For more help	Call HSE, 847-680-9930, for customer service phone assistance. Download manuals at hollandsafety.com .

Error Messages	Possible Cause	Action
Sensor Error	Cable not fitted correctly. Faulty Sensor. Faulty Cable. Faulty Controller.	Make sure the cable is firmly connected to the sensor and monitor. Try a replacement cable and sensor. For information on sensor voltages, contact Holland Safety.
Airflow difference between high and low air sample too low. Check sensor.	Sensor vent tube is not fitted or is kinked or sensor is obstructed.	Make sure the vent tube is fitted properly. Make sure the exhaust fan is running and the face velocity is 80 fpm or greater.
Deviations too high. Repeat low air sample. -or- Deviations too high. Repeat high air sample.	External influence such as window or supply grille blowing air onto the sensor. Faulty exhaust system giving an unstable face velocity.	Make sure there are no external influences disturbing the airflow through the sensor and that face velocity is stable. Once the sash is positioned and face velocity is measured, allow 30 seconds before entering the airflow sample.
Increase higher face velocity and repeat sample	The difference between the calibration points is too low.	Default minimum difference is 60 fpm. Decrease this value in the CalConfig menu if a higher difference is not achievable.

Sensor Data: In run mode, press +/- buttons to access diagnostics menu, select I/O status and then sensor data. With the fan off or sensor blocked, the reading should be around 80 to 90%. With the fan on, the reading should drop to at least 70%, ideally 60%. When the sash is lowered to increase face velocity to 200 fpm, expect a drop of another 10% to around 50%. If monitor does not display these values, there likely is a sensor installation issue.

TEL AFA 500 MK3 FUME HOOD MONITOR — INSTALLATION AND OPERATION GUIDE

STARTUP

The AFA 500 must be field-calibrated after an HVAC professional balances the room air supply and exhaust. When the unit is powered up, the following sequence of events occurs:

1. The alarm performs a self-test of its functions, LEDs and audible alarm (approximately 2 seconds) and then initiates a delay timer of 30 seconds to allow the airflow sensor to stabilize.
2. During the 30-second stabilizing period, all alarms and relay outputs are deactivated and the red and green LEDs remain on.
3. At the end of the delay, the unit will do one of two things:
 - a. **If the monitor has been calibrated**, the unit enters normal operating mode (solid green light for safe velocity, red light and audible alarm if low velocity).
 - b. **If the unit has not been calibrated**, the red and green LEDs will flash, the audible alarm will be muted.

CALIBRATION — SINGLE POINT (DEFAULT)

1. Determine the desired alarm point, then use a calibrated instrument to position the sash such that the face velocity of the hood is equivalent to the desired alarm point.
 2. Press and hold the ENTER button for 5 seconds to enter Calibration Mode. This is indicated by both red and green LEDs flashing with the audible alarm beeping.
 3. To initiate calibration, press and hold the ENTER and SET buttons at the same time. The unit will sample the airflow for 5 seconds, during which time the green LED goes off and the red LED flashes. The audible alarm continues to sound during the air sampling.
 4. If calibration is successful, the monitor will give a two-tone beep at the end of the air sample, and then automatically enter run mode.
 5. If the ENTER or SET button is released during the air sampling period, or if the airflow is fluctuating too much, the alarm will emit a lower-frequency buzzing for a short period and then re-enter calibration mode. If this occurs, press the ENTER and SET buttons again

to repeat the airflow sampling.

6. When calibration is complete, lower the sash to operating height and the green LED should light, indicating an airflow greater than the calibrated alarm point. If the airflow drops below the alarm point, the unit will go into alarm condition (red LED flashing, audible horn beeping).

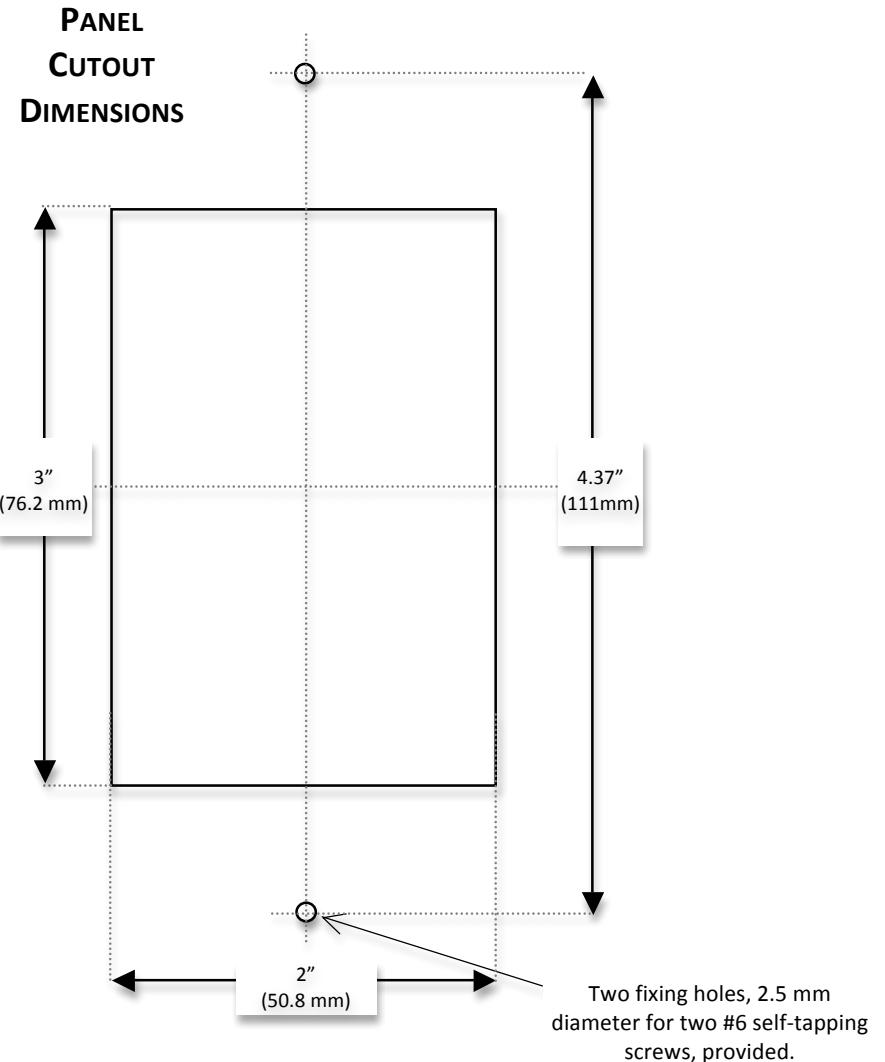
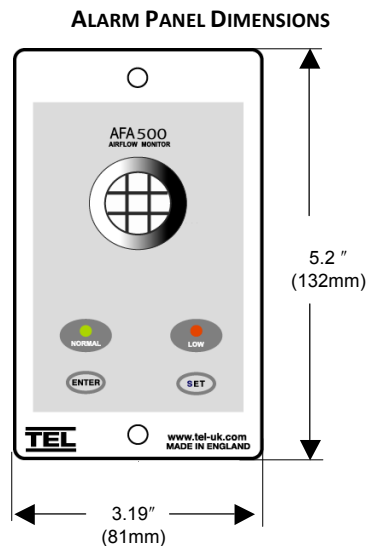

TEL AFA 500 MK3 FUME HOOD MONITOR — INSTALLATION AND OPERATION GUIDE

CONNECTION DETAILS

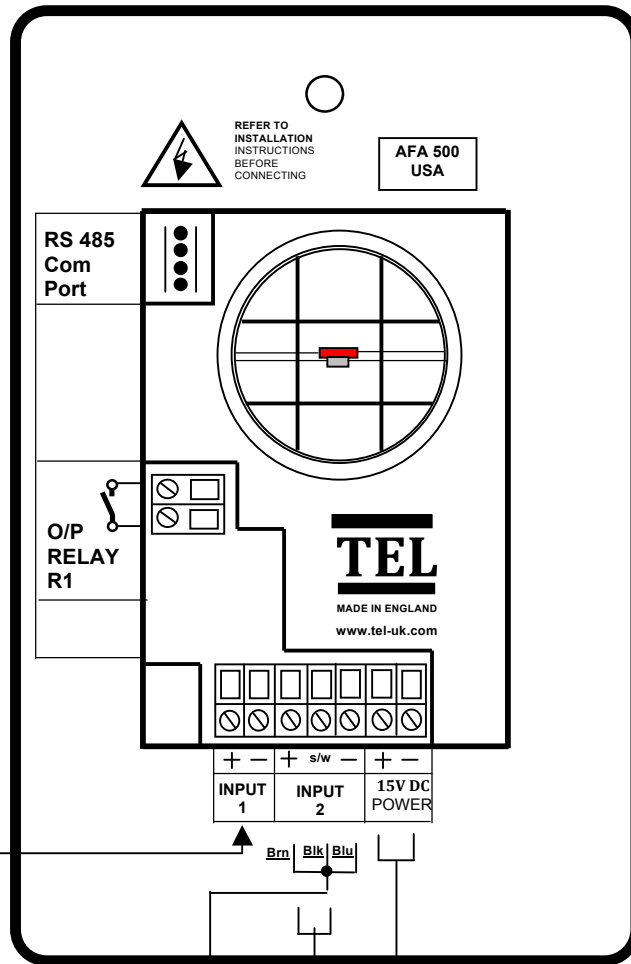

Night setback relay input

Sash High Micro-switch (Optional)

Sash High Proximity switch (Optional)

Flying lead with plug connection for PCB 15VDC

120V/15V DC Plug-in power adapter for 120V socket
Power requirement – 110mA @ 120VAC.

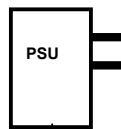

FRONT POST INSTALLATION

AFA 500 mounted on front of side post

Front of side post

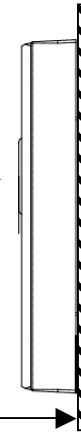

Loosen coupling Insert hose into coupling. Tighten coupling

25mm male thread c/w nut for fixing into inner side wall of the fume hood.

Adaptor 2 mounted through inner lining of side wall

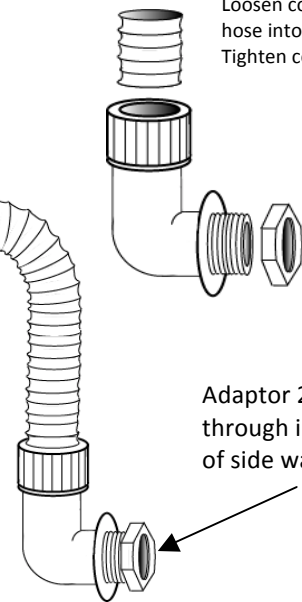

SIDEWALL SENSOR PLACEMENT

The monitor must be positioned where it can "see" the room pressure of the laboratory. The back connection spigot of the monitor will accept the provided air hose, which should be connected to the inner chamber of the fume hood. The **ideal position** for the other end of the hose, for most fume hoods, is 100mm (4 inches) back from the sash and 100mm higher than the normal sash opening height through the inner side wall.

Mount the monitor on the front of the fume hood and use the provided hose. For fume hoods with a single skin side wall or a double skin with a small gap between them, it may not be possible to achieve the ideal sensing position using the provided hose. With a single skin side wall it is possible to fix the sensor on the outside of the fume hood and connect directly to the inner chamber in the ideal position. This method can only be used for up to two fume hoods when they are positioned side by side (using the two outer walls).

The sensor should not be mounted in a position where it is subject to drafts from the laboratory air input or ventilation system.

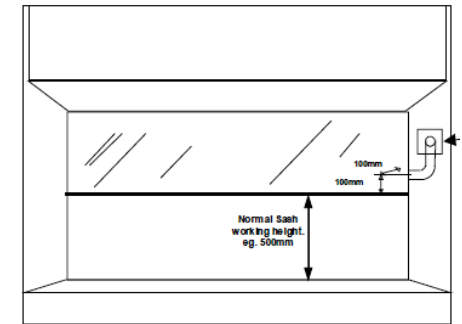

For complete manual and product information, log on to <http://www.tel-uk.com>. For support, call Holland Safety Equipment at 847-680-9930.

Muting the AFA 500

There are four ways to silence the audible alarm on an AFA 500 fume hood or bio-safety cabinet alarm.

1. Temporary mute

When the monitor is in alarm mode, press the enter button. The horn will remain off for the duration of the alarm condition. When the monitor returns to safe mode, the alarm will be re-enabled for the next time the monitor has an alarm condition.

For more information on the
TEL AFA 500 in North America,
contact Holland Safety Equipment
at 847-680-9930 or
info@hollandsafety.com



If the user wants to use a *temporary mute with a ringback feature* — wherein the audible alarm will resume after a set time period — this can be accomplished by connecting two wires from the relay output terminals to the + and SW terminals on the sash high input relay. Once this connection is made, an low air alarm also will initiate the sash high alarm. If a user pushes the enter button for a temporary mute, it will re-sound after five minutes.

2. Permanent mute

When the monitor is in normal operation mode, press and hold the set button for 10 seconds. The audible alarm will beep three times to indicate the alarm is disabled. When the airflow is in the normal/safe condition, the green LED will flash to indicate the alarm has been disabled. When the airflow is in a fail/unsafe condition, the red light will blink and no horn will sound. To undo the permanent mute, press and hold the set button for 10 seconds. The audible alarm will beep three times to indicate the alarm is enabled.

NOTE 1: This setting is not stored in the 500's flash memory, so permanent mute will reset in the event of a power loss.

3. Night Setback

This is a “temporary” mute activated by electric input. The monitor has two dry contact relay inputs on the back. To enable night setback, wire an external element (a building automation system or the hood power, the fan power, the room light, etc.) into relay input one. Then, when the external element changes states (turns on/turns off, etc.) it sends a signal to the relay to switch from open to closed. When the monitor enters night setback mode, the audible alarm is disabled. If there is sufficient airflow, the green light will blink. If there is an air fail condition, the red light will flash. Then, when the external element changes states back to the original condition, the relay switches back and the alarm returns to normal operating mode (the horn is re-activated automatically and the green light returns to solid state).

To make sure everything is set properly, activate the blower switch on and off while looking at

the monitor to make sure the mode is changing as intended.

This function is commonly used when the blower is switched off elsewhere, such as by a building automation system, which usually incorporates a volt free contact to mute the alarm.

When there is no automation system and the blower control is only a two-position switch in the room or on the hood, there must be a separate dry contact from the switch. The reason for this is the night setback function essentially switches its own voltage — one of the terminals on input 1 has the supply voltage on it (15VDC), this is then switched back into the other terminal to activate setback. If voltage from the blower switch is sent into input 1, the relay won't function as intended.

4. "Link" power

This approach involves wiring the monitor so when the power to an external source (such as the hood light) is shut off, the monitor powers off as well. This can be done by wiring the outlet that powers the monitor to lose power whenever the light loses power (kind of how a TV, DVD player, etc., all shut off when turning off the community surge protector/power strip). The monitor will remember its calibration when power is restored.

Here is a brief rundown of the five options for muting the audible alarm on an AFA 1000.

- 1. Temporary mute**
- 2. Permanent mute**
- 3. Night Setback**
- 4. Alarm Disable**
- 5. "Link" power**

1. Temporary mute

When the monitor is in alarm mode, press the enter button. The horn will remain off for the duration of the alarm condition. When the monitor returns to safe mode, the alarm will be re-enabled for the next time the monitor has an alarm condition. Users have the option of activating a timer for this temporary mute by following these steps:

1. Hold the enter button until you are given the choice between Run and Set Up. Choose Set Up.
2. Next, choose Configure (default password is 0-0-0-0).
3. Scroll down to Low Air Timer
4. Changed to Enabled
5. Set the timer (the default option is five minutes; the range is one to 30 minutes)
6. Select Done, this returns you to the main menu.
7. Select Run.

2. Permanent mute.

This is a "permanent" mute activated by going through the monitor's software via the following steps:

8. Hold the enter button until you are given the choice between Run and Set Up. Choose Set Up.
9. Next, choose Configure (default password is 0-0-0-0).
10. Next, choose CalConfig Menu
11. Then, scroll until you see Audible Alarm.
12. Change to Not Enabled, then press enter.
13. This returns you to the CalConfig Menu.
14. Select Done, this returns you to the main menu.
15. Select Run.
16. You should go back to the standard operation screen. There will be an icon of the horn with a slash through it and the green light will flash. When there is an alarm condition, the red light will flash and the display will alternate between the face velocity and AIR FAIL.

To undo the permanent silence, repeat the steps until you are in the Audible Alarm menu, and then change to Enabled.

3. Night Setback

This is a "temporary" mute activated by electric input. Your monitor has three dry contact relay inputs on the back. To enable Night Setback, you need to wire an external element (the hood power, the fan power, the room light, etc.) into one of the relay inputs. Then, when the external element changes states (turns on/turns off, etc.) it sends a signal to the relay to switch from open to closed. When the monitor enters Night Setback mode, the audible alarm is disabled. If there is an air fail, the red light will flash and the display will alternate between the velocity and "AIR FAIL." Then, when the external element changes states back to the original condition, the relay switches back and the alarm returns to normal operating mode (the horn is re-activated automatically).

These steps are what you do on the monitor assuming you have connected to input 1. You or the electrician will determine which state you want the relay to be in during normal operation mode, and then when the external element changes state, the relay will flip and the alarm will be disabled. In the case when relay contacts are set to normally open when the unit is in standard operation mode:

1. Hold the enter button until you are given the choice between Run and Set Up. Choose Set Up.
2. Next, choose Configure (password is 0-0-0-0).
3. Next, choose Input 1.
4. Select "contacts close on activation" and press enter. The monitor will display "Input 1 activation set" for two seconds and bring you to the next screen, which allows you to choose a function.
5. From here, you choose Night Setback. The monitor will display "Input 1 function set" for two seconds and then return you to the Config menu.
6. Once back in the Config menu, scroll to Night Setback Mute. Hit enter and set to "Enabled."
7. Select Done, this returns you to the main menu.
8. Select Run.
9. You should go back to the standard operation screen.

Then, to make sure everything is set properly, you must activate the blower switch on and off while looking at the monitor to make sure the mode is changing as you intend.

Once you've got this set up, no one has to physically do anything to the monitor for Night Setback mode to work. Simply flip the switch on whatever the external element is, and you're set.

It is possible to use an output relay to send a signal when the monitor enters Night Setback mode. By using the output from one monitor and the input to a second, and so on, it would be possible to put all the alarms in an entire lab into setback by activating one switch.

4. Alarm Disable

Like Night Setback, this also is a "temporary" mute activated by electric input. The prime difference is this option generally is controlled at the hood level whereas Night Setback is typically administered at the room level or externally via a building management system and a programmed schedule.

To enable Alarm Disable, wire an external element (in this case a switch, button or key switch) into one of the relay inputs. Then, when a user flips the switch or pushes the button, it sends a signal to the relay to switch from open to closed. That will disable the audible alarm and the LCD screen will read "ALARM DISABLE."

The activation process is identical to Night Setback (above), except that in Step 5 Alarm Disable is chosen as the function.

This method most often is deployed at times when the sash must be open for extended periods for loading materials in or out of the hood or during service work. Also like Night Setback, the feature may be daisy-chained to other monitors using the output relay of the lead monitor and the input of a follower.

5. "Link" power

The idea here is for someone to wire the monitor so that when the power to an external source (say, the room or hood lights) is shut off, the monitor powers off as well. You can either do that electrically, by connecting wires, or you can do it the "layman's way," by making sure the outlet that powers the monitor loses power whenever the hood itself loses power (kind of how a TV, DVD player, etc., all shut off as you turn off the surge protector/power strip).

A note on input relays

The AFA 1000 has 3 inputs — these are digital, meaning open or closed, two-wire relays. They are dry contacts; they need no external voltage on them because the monitor itself provides the voltage that is then switched back in.

The inputs have two terminals, + & SW. The + is internally connected to the + of the power supply on the AFA (there are some EMC components connected but we can consider them directly linked). As the power supply is 15VDC there is then 15VDC (approximately) on each + input terminal.

When the + terminal is connected to the SW terminal (input closed) we are simply connecting the 15VDC back into the SW terminal, this then is indirectly fed to the microprocessor to activate the assigned input function.

In other words, you can fit a simple link wire to the two terminals; this will activate the input.

Typically the link wire is a micro switch (mechanical switch) or signal from the building automation system (dry relay contact) in the field. If you put any external (other source) voltage into the inputs it will damage the AFA — it uses its own voltage.

In the UK it is fairly commonplace to have a blower switch with an auxiliary (spare) isolated contact, a switch with two sets of contacts.

Another solution is to fit a remote 120V relay that is switched from the blower switch, then use a dry contact from the relay to connect to the monitor.