

# Titan Series Adaptable Systems

product catalog







Since 1975, Air Master Systems has manufactured chemical fume hoods, filtration hoods, and laboratory furniture for the R&D, institutional, industrial, government and biotech markets.



# Contents

<b>Titan Core Systems</b>	<b>4</b>
<b>Titan T12</b>	<b>5</b>
Load Ratings	5
Box Core	6
Lower Box Core	7
<b>Titan T9</b>	<b>8</b>
Load Ratings	8
Box Core	9
Lower Box Core	10
<b>Titan T6</b>	<b>11</b>
Load Ratings	11
Box Core	12
Lower Box Core	13
<b>Titan T3</b>	<b>14</b>
Load Ratings	14
Island Panel Box Core	15
Island Panel Lower Box Core	16
Wall Panel Box Core	17
Wall Panel Lower Box Core	18
Island Shelf System	19
<b>Titan Box Frame</b>	<b>20</b>
Box Frame Assembly	20
Box Frame	21
Box Frame Shared	22
<b>Titan Side Removable Panels</b>	<b>23</b>
<b>Titan Shelf Kits</b>	<b>24</b>
Standard Depth Kits	24
Extended Depth Kits	25
Standard Bracket Kits	26
Inner Shelf Kits	26
<b>Cantilever Table Frame</b>	<b>27</b>
<b>Wall Rails</b>	<b>28</b>
Load Ratings	28
Wall Rails System	29
<b>Standard Titan Wall Shelf Kits</b>	<b>30</b>
<b>Wall Standards</b>	<b>31</b>
<b>Heavy Duty Wall Rails</b>	<b>32</b>
Load Ratings	32
Heavy Duty Wall Rails	33
<b>Heavy Duty Shelf Kits</b>	<b>34</b>
<b>Titan Mobile Carts</b>	<b>35</b>
Load Ratings	35
Mobile Carts	36
<b>Titan Mobile Cart Components</b>	<b>37</b>
<b>Heavy Duty Mobile Carts</b>	<b>38</b>
Load Ratings	38
Mobile Carts	39
<b>Heavy Duty Mobile Cart Components</b>	<b>40</b>
<b>Titan Work Bench</b>	<b>41</b>
Work Bench (No Services)	41
Work Bench (With Services)	42
Work Bench (Double-Sided)	43
<b>Table Frame</b>	<b>44</b>
<b>Titan Systems Accessories</b>	<b>45</b>
Titan Raceway	45
Titan Hanging Rail Kit	45
<b>Under Shelf Task Lights</b>	<b>46</b>
ECON Light	46
TUCK Light	47

**Note:**

Images in this catalog are for representation only. For complete product specifications, contact your AMS representative.

# Titan Core Systems

---

The complete versatility of the Titan Core System will handle a multitude of functions in the laboratory environment. The system is extremely adaptable and durable to exceed your laboratory needs. The core has slotted uprights for shelving, table frames, and cabinet options.



## Key Features

- Titan Core System configurations can be readily created and easily changed as well as moved for new applications or changing space.
- Can be used in conjunction with suspended, mobile or floor-mounted casework.
- Solid durable construction
- Includes a fine adjust leveling foot
- Static capacity of 2600lbs (on a double sided, four shelves, two table frame unit) SEFA tested
- Cantilever table frames available in depths of 24" & 30"
- Available in: 24", 30", 36" 42", 48", 54", 60", 72"
- Cabinets: mobile, suspended, or floor mounted ordered separately
- Counter top options available in Phenolic & Epoxy
- Order shelving separately. Shelf brackets are adjustable in 1" increments to allow for multiple configurations. Shelf depths vary based on necessity.
- Standard shelves are 12", 14", 16" , and 18" deep. Shelves can be flush to the core uprights or inset 6" between core uprights. 12" inner shelves available to work in conjunction with standard exterior shelves.



# Titan T12 - Box Core

The Titan T12 box core is 84 5/16" tall and available from 24" to 72" wide, with levelers having 1" of adjustment. The unit is floor mounted for wall or island configurations. The box core has components such as: shelving, cantilever frame, structural cantilever table, and suspended cabinets. All components attaching to the core are ordered separately. Electrical, data or plumbing services are available in lower fixed and reagent panels.

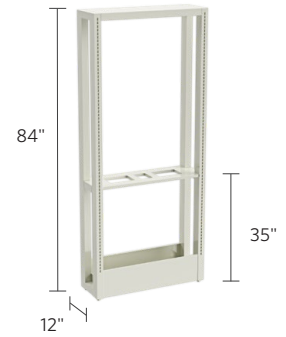

## T12 BOX CORE LOAD RATINGS

Parts	Loading Rate
Top Shelf	100lbs
Shelving	200lbs
Suspended Cabinet	300lbs
Upper Suspended Cabinet	300lbs
Cantilevered Table Work Frame	800lbs
Total Core Assembly	2,500lbs



# Titan T12 - Box Core

The Titan T12 box core is 84 5/16" High, available from 24" to 72" wide, and has levelers with 1" adjustment. The unit is floor mounted making it suitable for wall or island configurations, where general services are needed. The box core has components such as inserts, shelves, cantilever table, structural cantilever table, and suspended cabinets. All the components are ordered separately. Another feature is the option of having removable panels and to indicate removable panels change (0) to (2). For epoxy or phenolic tops, replace N for E or P respectively. Electrical services are available in lower fixed and reagent panels. For more information please contact sales representatives.

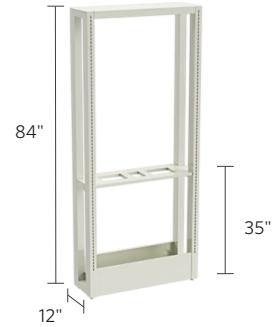

## 12" DEPTH BOX CORE - FULL HEIGHT



No Lower Removable Panels

Width	Item Number
24"	T12-BC-2484-0N
30"	T12-BC-3084-0N
36"	T12-BC-3684-0N
42"	T12-BC-4284-0N
48"	T12-BC-4884-0N
54"	T12-BC-5484-0N
60"	T12-BC-6084-0N
66"	T12-BC-6684-0N
72"	T12-BC-7284-0N



With Lower Removable Panels

Width	Item Number
24"	T12-BC-2484-2N
30"	T12-BC-3084-2N
36"	T12-BC-3684-2N
42"	T12-BC-4284-2N
48"	T12-BC-4884-2N
54"	T12-BC-5484-2N
60"	T12-BC-6084-2N
66"	T12-BC-6684-2N
72"	T12-BC-7284-2N

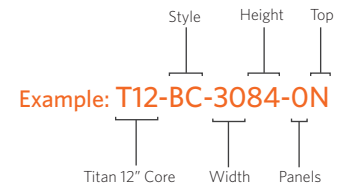

## 12" DEPTH REAGENT BOX CORE - FULL HEIGHT

The reagent box core is featuring a 12" tall reagent panel.

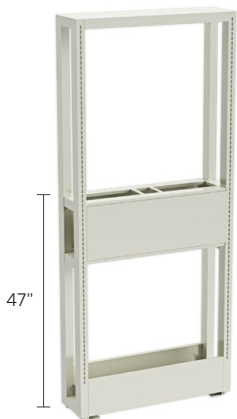

No Lower Removable Panels

Width	Item Number
24"	T12-RBC-2484-0N
30"	T12-RBC-3084-0N
36"	T12-RBC-3684-0N
42"	T12-RBC-4284-0N
48"	T12-RBC-4884-0N
54"	T12-RBC-5484-0N
60"	T12-RBC-6084-0N
66"	T12-RBC-6684-0N
72"	T12-RBC-7284-0N



With Lower Removable Panels

Width	Item Number
24"	T12-RBC-2484-2N
30"	T12-RBC-3084-2N
36"	T12-RBC-3684-2N
42"	T12-RBC-4284-2N
48"	T12-RBC-4884-2N
54"	T12-RBC-5484-2N
60"	T12-RBC-6084-2N
66"	T12-RBC-6684-2N
72"	T12-RBC-7284-2N



# Titan T12 — Lower Box Core

The Titan T12 lower box core is 35 or 47" tall and available from 24" to 72" wide, with levelers having 1" of adjustment. The unit is floor mounted for wall or island configurations. The lower box core has components such as: shelving, cantilever frame, structural cantilever table, and suspended cabinets. All components attaching to the core are ordered separately. Electrical, data or plumbing services are available in lower fixed and reagent panels.

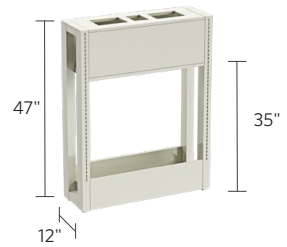

## 12" DEPTH BOX CORE - LOWER HEIGHT



No Lower Removable Panels

Width	Item Number
24"	T12-LC-2435-0N
30"	T12-LC-3035-0N
36"	T12-LC-3635-0N
42"	T12-LC-4235-0N
48"	T12-LC-4835-0N
54"	T12-LC-5435-0N
60"	T12-LC-6035-0N
66"	T12-LC-6635-0N
72"	T12-LC-7235-0N



With Lower Removable Panels

Width	Item Number
24"	T12-LC-2435-2N
30"	T12-LC-3035-2N
36"	T12-LC-3635-2N
42"	T12-LC-4235-2N
48"	T12-LC-4835-2N
54"	T12-LC-5435-2N
60"	T12-LC-6035-2N
66"	T12-LC-6635-2N
72"	T12-LC-7235-2N

## 12" DEPTH REAGENT BOX CORE - LOWER HEIGHT

The reagent box core is featuring a 12" tall reagent panel.



No Lower Removable Panels

Width	Item Number
24"	T12-RLC-2447-0N
30"	T12-RLC-3047-0N
36"	T12-RLC-3647-0N
42"	T12-RLC-4247-0N
48"	T12-RLC-4847-0N
54"	T12-RLC-5447-0N
60"	T12-RLC-6047-0N
66"	T12-RLC-6647-0N
72"	T12-RLC-7247-0N



With Lower Removable Panels

Width	Item Number
24"	T12-RLC-2447-2N
30"	T12-RLC-3047-2N
36"	T12-RLC-3647-2N
42"	T12-RLC-4247-2N
48"	T12-RLC-4847-2N
54"	T12-RLC-5447-2N
60"	T12-RLC-6047-2N
66"	T12-RLC-6647-2N
72"	T12-RLC-7247-2N

# Titan T9 - Box Core

The Titan T9 box core is 84 5/16" tall and available from 24" to 72" wide, with levelers having 1" of adjustment. The unit is floor mounted for wall configurations. The box core has components such as: shelving, cantilever frame, structural cantilever table, and suspended cabinets. All components attaching to the core are ordered separately. Electrical, data or plumbing services are available in lower fixed and reagent panels.

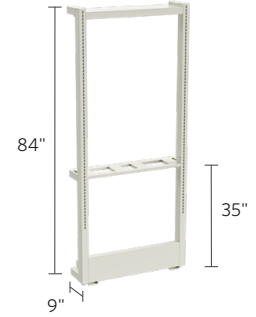

## T9 BOX CORE LOAD RATINGS

Parts	Loading Rate
Top Shelf	100lbs
Shelving	200lbs
Cantilevered Table Work Frame	800lbs
Total Core Assembly	1,300lbs





# Titan T9 — Box Core

Style      Height      Top  
**Example: T9-BC-3084-0N**  
Titan 9" Core      Width      Panels

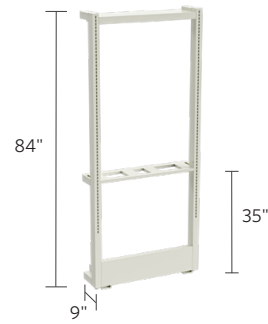

## 9" DEPTH BOX CORE - FULL HEIGHT



No Lower Removable Panels

Width	Item Number
24"	T9-BC-2484-0N
30"	T9-BC-3084-0N
36"	T9-BC-3684-0N
42"	T9-BC-4284-0N
48"	T9-BC-4884-0N
54"	T9-BC-5484-0N
60"	T9-BC-6084-0N
66"	T9-BC-6684-0N
72"	T9-BC-7284-0N



With Lower Removable Panels

Width	Item Number
24"	T9-BC-2484-2N
30"	T9-BC-3084-2N
36"	T9-BC-3684-2N
42"	T9-BC-4284-2N
48"	T9-BC-4884-2N
54"	T9-BC-5484-2N
60"	T9-BC-6084-2N
66"	T9-BC-6684-2N
72"	T9-BC-7284-2N

## 9" DEPTH REAGENT BOX CORE - FULL HEIGHT

The reagent box core is featuring a 12" tall reagent panel.



No Lower Removable Panels

Width	Item Number
24"	T9-RBC-2484-0N
30"	T9-RBC-3084-0N
36"	T9-RBC-3684-0N
42"	T9-RBC-4284-0N
48"	T9-RBC-4884-0N
54"	T9-RBC-5484-0N
60"	T9-RBC-6084-0N
66"	T9-RBC-6684-0N
72"	T9-RBC-7284-0N



With Lower Removable Panels

Width	Item Number
24"	T9-RBC-2484-2N
30"	T9-RBC-3084-2N
36"	T9-RBC-3684-2N
42"	T9-RBC-4284-2N
48"	T9-RBC-4884-2N
54"	T9-RBC-5484-2N
60"	T9-RBC-6084-2N
66"	T9-RBC-6684-2N
72"	T9-RBC-7284-2N

# Titan T9 — Lower Box Core

Designed for wall configurations where services and are required. Electrical, data or plumbing services including cup sinks can be accommodated.

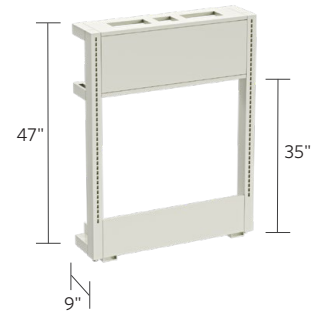

## 9" DEPTH BOX CORE - LOWER HEIGHT



No Lower Removable Panels

Width	Item Number
24"	T9-LC-2435-0N
30"	T9-LC-3035-0N
36"	T9-LC-3635-0N
42"	T9-LC-4235-0N
48"	T9-LC-4835-0N
54"	T9-LC-5435-0N
60"	T9-LC-6035-0N
66"	T9-LC-6635-0N
72"	T9-LC-7235-0N



With Lower Removable Panels

Width	Item Number
24"	T9-LC-2435-2N
30"	T9-LC-3035-2N
36"	T9-LC-3635-2N
42"	T9-LC-4235-2N
48"	T9-LC-4835-2N
54"	T9-LC-5435-2N
60"	T9-LC-6035-2N
66"	T9-LC-6635-2N
72"	T9-LC-7235-2N

## 9" DEPTH REAGENT BOX CORE - LOWER HEIGHT

The reagent box core is featuring a 12" tall reagent panel.



No Lower Removable Panels

Width	Item Number
24"	T9-RLC-2447-0N
30"	T9-RLC-3047-0N
36"	T9-RLC-3647-0N
42"	T9-RLC-4247-0N
48"	T9-RLC-4847-0N
54"	T9-RLC-5447-0N
60"	T9-RLC-6047-0N
66"	T9-RLC-6647-0N
72"	T9-RLC-7247-0N

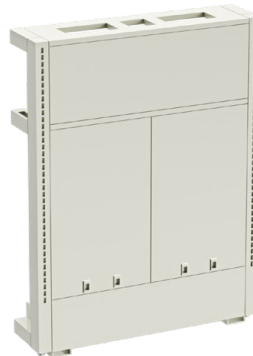

With Lower Removable Panels

Width	Item Number
24"	T9-RLC-2447-2N
30"	T9-RLC-3047-2N
36"	T9-RLC-3647-2N
42"	T9-RLC-4247-2N
48"	T9-RLC-4847-2N
54"	T9-RLC-5447-2N
60"	T9-RLC-6047-2N
66"	T9-RLC-6647-2N
72"	T9-RLC-7247-2N



# Titan T6 - Box Core

The Titan T6 box core is 84 5/16" tall and available from 24" to 72" wide, with levelers having 1" of adjustment. The unit is floor mounted for wall or island configurations. The box core has components such as: shelving, cantilever frame, structural cantilever table, and suspended cabinets. All components attaching to the core are ordered separately. Electrical, data or plumbing services are available in lower fixed and reagent panels.

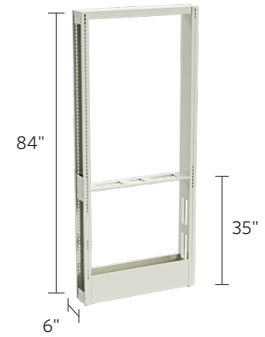

## T6 BOX CORE LOAD RATINGS

Parts	Loading Rate
Top Shelf	100lbs
Shelving	200lbs
Suspended Cabinet	300lbs
Upper Suspended Cabinet	300lbs
Structural Cantilevered Table Frame	800lbs
Total Core Assembly	2,500lbs

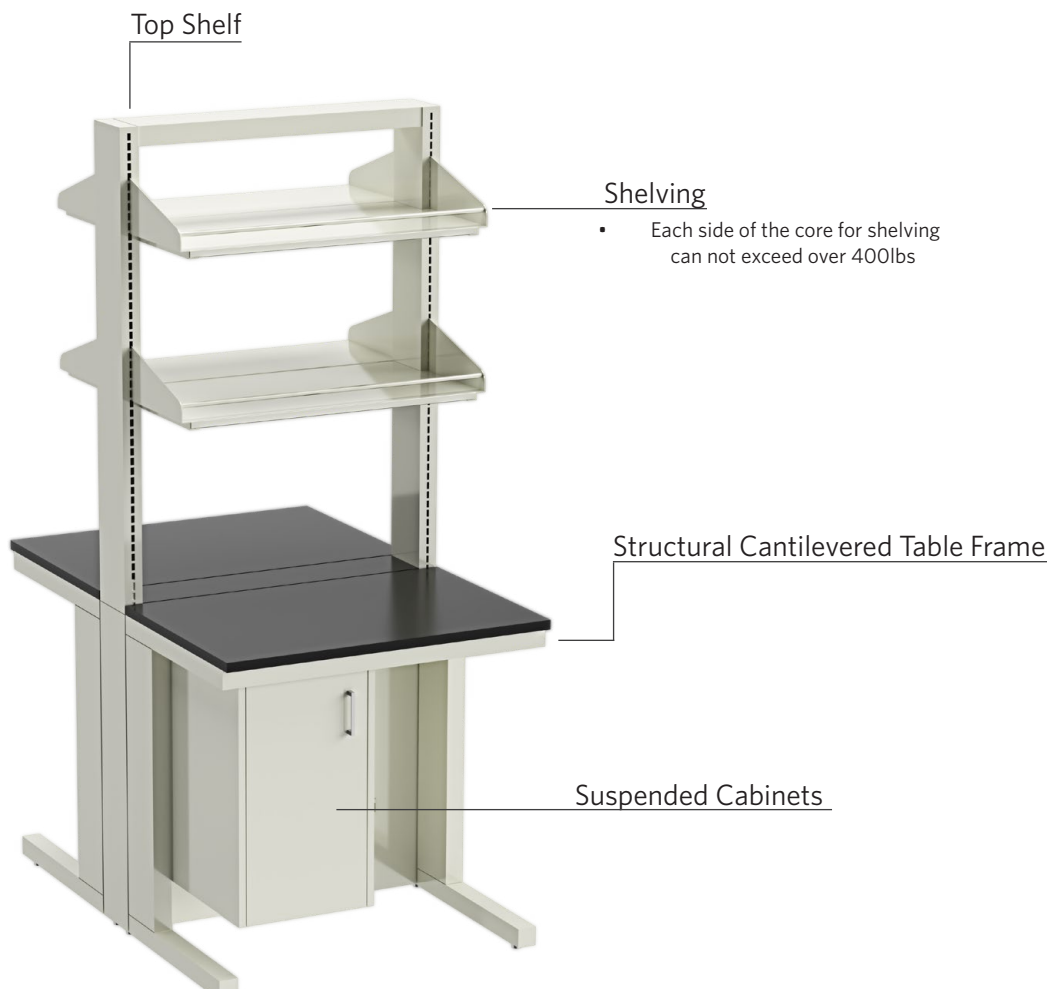

# Titan T6 — Box Core

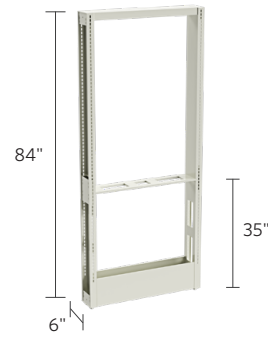
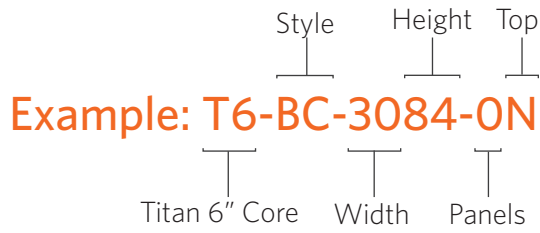

## 6" DEPTH BOX CORE - FULL HEIGHT



No Lower Removable Panels

Width	Item Number
24"	T6-BC-2484-ON
30"	T6-BC-3084-ON
36"	T6-BC-3684-ON
42"	T6-BC-4284-ON
48"	T6-BC-4884-ON
54"	T6-BC-5484-ON
60"	T6-BC-6084-ON
66"	T6-BC-6684-ON
72"	T6-BC-7284-ON



With Lower Removable Panels

Width	Item Number
24"	T6-BC-2484-2N
30"	T6-BC-3084-2N
36"	T6-BC-3684-2N
42"	T6-BC-4284-2N
48"	T6-BC-4884-2N
54"	T6-BC-5484-2N
60"	T6-BC-6084-2N
66"	T6-BC-6684-2N
72"	T6-BC-7284-2N

## 9" DEPTH REAGENT BOX CORE - FULL HEIGHT

The reagent box core is featuring a 12" tall reagent panel.

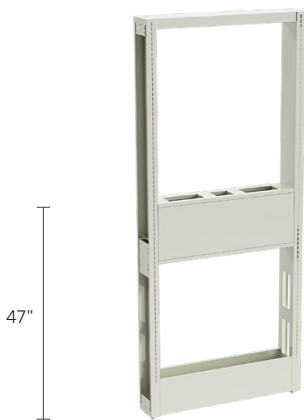

No Lower Removable Panels

Width	Item Number
24"	T6-RBC-2484-ON
30"	T6-RBC-3084-ON
36"	T6-RBC-3684-ON
42"	T6-RBC-4284-ON
48"	T6-RBC-4884-ON
54"	T6-RBC-5484-ON
60"	T6-RBC-6084-ON
66"	T6-RBC-6684-ON
72"	T6-RBC-7284-ON



With Lower Removable Panels

Width	Item Number
24"	T6-RBC-2484-2N
30"	T6-RBC-3084-2N
36"	T6-RBC-3684-2N
42"	T6-RBC-4284-2N
48"	T6-RBC-4884-2N
54"	T6-RBC-5484-2N
60"	T6-RBC-6084-2N
66"	T6-RBC-6684-2N
72"	T6-RBC-7284-2N

# Titan T6 — Lower Box Core

The Titan T6 lower box core is 35 or 47" tall and available from 24" to 72" wide, with levelers having 1" of adjustment. The unit is floor mounted for wall or island configurations. The lower box core has components such as: shelving, cantilever frame, structural cantilever table, and suspended cabinets. All components attaching to the core are ordered separately. Electrical, data or plumbing services are available in lower fixed and reagent panels.

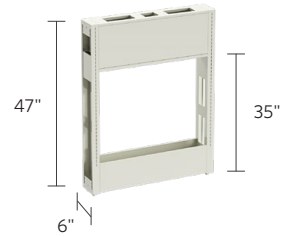

## 6" DEPTH BOX CORE - LOWER HEIGHT



No Lower Removable Panels

Width	Item Number
24"	T6-LC-2435-0N
30"	T6-LC-3035-0N
36"	T6-LC-3635-0N
42"	T6-LC-4235-0N
48"	T6-LC-4835-0N
54"	T6-LC-5435-0N
60"	T6-LC-6035-0N
66"	T6-LC-6635-0N
72"	T6-LC-7235-0N



With Lower Removable Panels

Width	Item Number
24"	T6-LC-2435-2N
30"	T6-LC-3035-2N
36"	T6-LC-3635-2N
42"	T6-LC-4235-2N
48"	T6-LC-4835-2N
54"	T6-LC-5435-2N
60"	T6-LC-6035-2N
66"	T6-LC-6635-2N
72"	T6-LC-7235-2N

## 6" DEPTH REAGENT BOX CORE - LOWER HEIGHT

The reagent box core is featuring a 12" tall reagent panel.



No Lower Removable Panels

Width	Item Number
24"	T6-RLC-2447-0N
30"	T6-RLC-3047-0N
36"	T6-RLC-3647-0N
42"	T6-RLC-4247-0N
48"	T6-RLC-4847-0N
54"	T6-RLC-5447-0N
60"	T6-RLC-6047-0N
66"	T6-RLC-6647-0N
72"	T6-RLC-7247-0N



With Lower Removable Panels

Width	Item Number
24"	T6-RLC-2447-2N
30"	T6-RLC-3047-2N
36"	T6-RLC-3647-2N
42"	T6-RLC-4247-2N
48"	T6-RLC-4847-2N
54"	T6-RLC-5447-2N
60"	T6-RLC-6047-2N
66"	T6-RLC-6647-2N
72"	T6-RLC-7247-2N

# Titan T3 - Box Core

The Titan T3 box core is 84 5/16" tall and available from 24" to 72" wide, with levelers having 1" of adjustment. The unit is floor mounted for wall or island configurations. The box core has components such as: shelving, cantilever frame, structural cantilever table, and suspended cabinets. All components attaching to the core are ordered separately. Electrical, data or plumbing services are available in lower fixed and reagent panels.

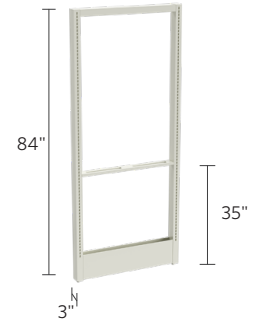

## T3 BOX CORE LOAD RATINGS

Parts	Loading Rate
Shelving	180lbs
Suspended Cabinet	300lbs
Upper Suspended Cabinet	300lbs
Structural Cantilevered Table Frame	800lbs
Total Core Assembly	1,520lbs





# Titan T3 — Island Panel Box Core

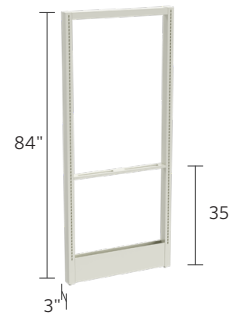
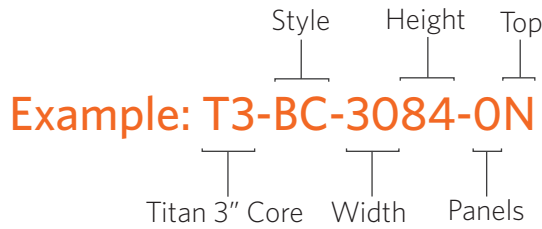

## 3" DEPTH BOX CORE - FULL HEIGHT



No Lower Removable Panels

Width	Item Number
24"	T3-IPBC-2484-ON
30"	T3-IPBC-3084-ON
36"	T3-IPBC-3684-ON
42"	T3-IPBC-4284-ON
48"	T3-IPBC-4884-ON
54"	T3-IPBC-5484-ON
60"	T3-IPBC-6084-ON
66"	T3-IPBC-6684-ON
72"	T3-IPBC-7284-ON



With Lower Removable Panels

Width	Item Number
24"	T3-IPBC-2484-2N
30"	T3-IPBC-3084-2N
36"	T3-IPBC-3684-2N
42"	T3-IPBC-4284-2N
48"	T3-IPBC-4884-2N
54"	T3-IPBC-5484-2N
60"	T3-IPBC-6084-2N
66"	T3-IPBC-6684-2N
72"	T3-IPBC-7284-2N

## 3" DEPTH REAGENT BOX CORE - FULL HEIGHT

The reagent box core is featuring a 12" tall reagent panel.

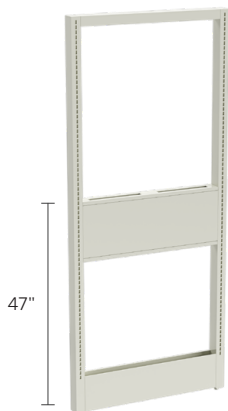

No Lower Removable Panels

Width	Item Number
24"	T3-IPRBC-2484-ON
30"	T3-IPRBC-3084-ON
36"	T3-IPRBC-3684-ON
42"	T3-IPRBC-4284-ON
48"	T3-IPRBC-4884-ON
54"	T3-IPRBC-5484-ON
60"	T3-IPRBC-6084-ON
66"	T3-IPRBC-6684-ON
72"	T3-IPRBC-7284-ON



With Lower Removable Panels

Width	Item Number
24"	T3-IPRBC-2484-2N
30"	T3-IPRBC-3084-2N
36"	T3-IPRBC-3684-2N
42"	T3-IPRBC-4284-2N
48"	T3-IPRBC-4884-2N
54"	T3-IPRBC-5484-2N
60"	T3-IPRBC-6084-2N
66"	T3-IPRBC-6684-2N
72"	T3-IPRBC-7284-2N

# Titan T3 — Island Panel Lower Box Core

The Titan T3 lower island box core is 35 or 47" tall and available from 24" to 72" wide, with levelers having 1" of adjustment. The unit is floor mounted for wall or island configurations. The lower box core has components such as: shelving, cantilever frame, structural cantilever table, and suspended cabinets. All components attaching to the core are ordered separately. Electrical, data or plumbing services are available in lower fixed and reagent panels.

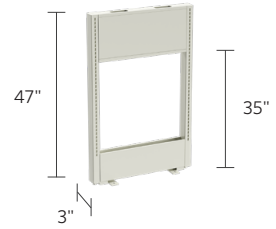

## 3" DEPTH BOX CORE - LOWER HEIGHT



No Lower Removable Panels

Width	Item Number
24"	T3-IPLC-2435-0N
30"	T3-IPLC-3035-0N
36"	T3-IPLC-3635-0N
42"	T3-IPLC-4235-0N
48"	T3-IPLC-4835-0N
54"	T3-IPLC-5435-0N
60"	T3-IPLC-6035-0N
66"	T3-IPLC-6635-0N
72"	T3-IPLC-7235-0N



With Lower Removable Panels

Width	Item Number
24"	T3-IPLC-2435-2N
30"	T3-IPLC-3035-2N
36"	T3-IPLC-36352N
42"	T3-IPLC-4235-2N
48"	T3-IPLC-4835-2N
54"	T3-IPLC-5435-2N
60"	T3-IPLC-6035-2N
66"	T3-IPLC-66352N
72"	T3-IPLC-7235-2N

## 3" DEPTH REAGENT BOX CORE - FULL HEIGHT

The reagent box core is featuring a 12" tall reagent panel.



No Lower Removable Panels

Width	Item Number
24"	T3-IPRLC-2447-0N
30"	T3-IPRLC-3047-0N
36"	T3-IPRLC-3647-0N
42"	T3-IPRLC-4247-0N
48"	T3-IPRLC-4847-0N
54"	T3-IPRLC-5447-0N
60"	T3-IPRLC-6047-0N
66"	T3-IPRLC-6647-0N
72"	T3-IPRLC-7247-0N

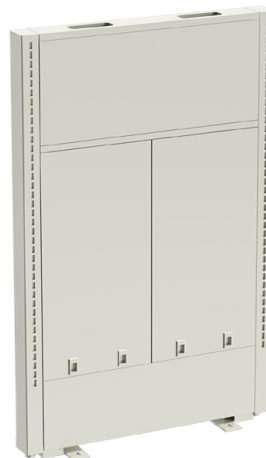

With Lower Removable Panels

Width	Item Number
24"	T3-IPRLC-2447-2N
30"	T3-IPRLC-3047-2N
36"	T3-IPRLC-3647-2N
42"	T3-IPRLC-4247-2N
48"	T3-IPRLC-4847-2N
54"	T3-IPRLC-5447-2N
60"	T3-IPRLC-6047-2N
66"	T3-IPRLC-6647-2N
72"	T3-IPRLC-7247-2N

# Titan T3 — Wall Panel Box Core

The Titan T3 wall panel box core is 84 5/16" tall and available from 24" to 72" wide, with levelers having 1" of adjustment. The unit is floor mounted for wall configurations. The box core has components such as: shelving, cantilever frame, structural cantilever table, and suspended cabinets. All components attaching to the core are ordered separately. Electrical, data or plumbing services are available in lower fixed and reagent panels.

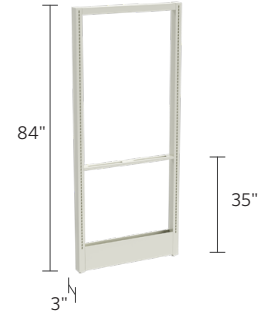

## 3" DEPTH BOX CORE - FULL HEIGHT



No Lower Removable Panels

Width	Item Number
24"	T3-WPBC-2484-0N
30"	T3-WPBC-3084-0N
36"	T3-WPBC-3684-0N
42"	T3-WPBC-4284-0N
48"	T3-WPBC-4884-0N
54"	T3-WPBC-5484-0N
60"	T3-WPBC-6084-0N
66"	T3-WPBC-6684-0N
72"	T3-WPBC-7284-0N



With Lower Removable Panels

Width	Item Number
24"	T3-WPBC-2484-1N
30"	T3-WPBC-3084-1N
36"	T3-WPBC-3684-1N
42"	T3-WPBC-4284-1N
48"	T3-WPBC-4884-1N
54"	T3-WPBC-5484-1N
60"	T3-WPBC-6084-1N
66"	T3-WPBC-6684-1N
72"	T3-WPBC-7284-1N

## 3" DEPTH REAGENT BOX CORE - FULL HEIGHT

The reagent box core is featuring a 12" tall reagent panel.

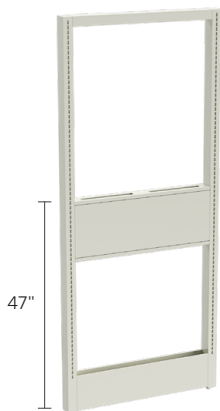

No Lower Removable Panels

Width	Item Number
24"	T3-WPRBC-2484-0N
30"	T3-WPRBC-3084-0N
36"	T3-WPRBC-3684-0N
42"	T3-WPRBC-4284-0N
48"	T3-WPRBC-4884-0N
54"	T3-WPRBC-5484-0N
60"	T3-WPRBC-6084-0N
66"	T3-WPRBC-6684-0N
72"	T3-WPRBC-7284-0N



With Lower Removable Panels

Width	Item Number
24"	T3-WPRBC-2484-1N
30"	T3-WPRBC-3084-1N
36"	T3-WPRBC-3684-1N
42"	T3-WPRBC-4284-1N
48"	T3-WPRBC-4884-1N
54"	T3-WPRBC-5484-1N
60"	T3-WPRBC-6084-1N
66"	T3-WPRBC-6684-1N
72"	T3-WPRBC-7284-1N

# Titan T3 — Wall Panel Lower Box Core

The Titan T3 wall panel lower box core is 35 or 47" tall and available 24" to 72" wide with levelers having 1" of adjustment. The unit is floor mounted for wall configurations. The lower box core has components such as: shelving, cantilever frame, structural cantilever table, and suspended cabinets. All components attaching to the core are ordered separately. Electrical, data or plumbing services are available in lower fixed and reagent panels.

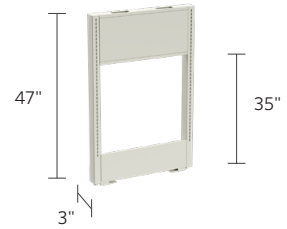

## 3" DEPTH BOX CORE - LOWER HEIGHT



No Lower Removable Panels

Width	Item Number
24"	T3-WPLC-2435-0N
30"	T3-WPLC-3035-0N
36"	T3-WPLC-3635-0N
42"	T3-WPLC-4235-0N
48"	T3-WPLC-4835-0N
54"	T3-WPLC-5435-0N
60"	T3-WPLC-6035-0N
66"	T3-WPLC-6635-0N
72"	T3-WPLC-7235-0N



With Lower Removable Panels

Width	Item Number
24"	T3-WPLC-2435-1N
30"	T3-WPLC-3035-1N
36"	T3-WPLC-3635-1N
42"	T3-WPLC-4235-1N
48"	T3-WPLC-4835-1N
54"	T3-WPLC-5435-1N
60"	T3-WPLC-6035-1N
66"	T3-WPLC-6635-1N
72"	T3-WPLC-7235-1N

## 3" DEPTH REAGENT BOX CORE - FULL HEIGHT

The reagent box core is featuring a 12" tall reagent panel.



No Lower Removable Panels

Width	Item Number
24"	T3-WPRLC-2447-0N
30"	T3-WPRLC-3047-0N
36"	T3-WPRLC-3647-0N
42"	T3-WPRLC-4247-0N
48"	T3-WPRLC-4847-0N
54"	T3-WPRLC-5447-0N
60"	T3-WPRLC-6047-0N
66"	T3-WPRLC-6647-0N
72"	T3-WPRLC-7247-0N

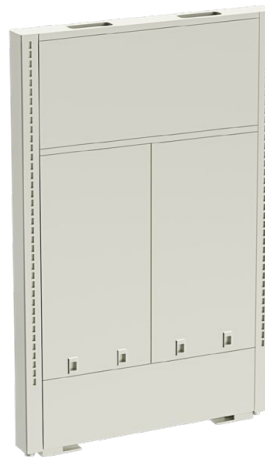

With Lower Removable Panels

Width	Item Number
24"	T3-WPRLC-2447-1N
30"	T3-WPRLC-3047-1N
36"	T3-WPRLC-3647-1N
42"	T3-WPRLC-4247-1N
48"	T3-WPRLC-4847-1N
54"	T3-WPRLC-5447-1N
60"	T3-WPRLC-6047-1N
66"	T3-WPRLC-6647-1N
72"	T3-WPRLC-7247-1N



# Titan T3 — Island Shelf System

The Titan T3 island upright system is designed for 2 shelf brackets to fit into 1 upright. The intent of the design is for shelving in an island assembly.

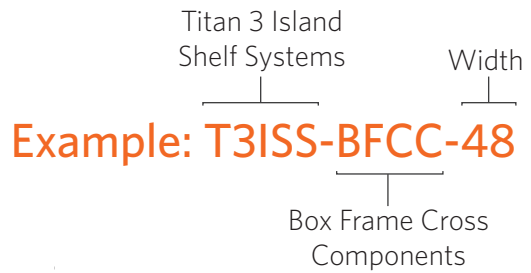
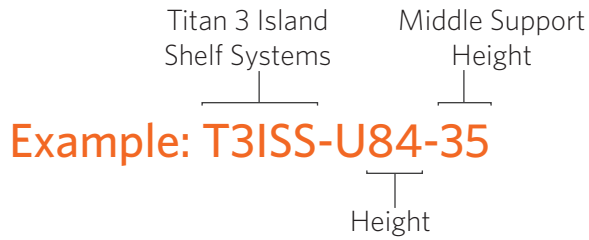

## T3 ISLAND SHELF SYSTEM

Parts	Loading Rate
Shelving	180lbs
Maximum Per Side	240lbs
Total Island Assembly	480lbs



Middle Support Height	Item Number
29"	T3ISS-U84-29
35"	T3ISS-U84-35

Width	Item Number
24"	T3ISS-BFCC-24
30"	T3ISS-BFCC-30
36"	T3ISS-BFCC-36
42"	T3ISS-BFCC-42
48"	T3ISS-BFCC-48
54"	T3ISS-BFCC-54
60"	T3ISS-BFCC-60
66"	T3ISS-BFCC-66
72"	T3ISS-BFCC-72

BFCC Kits include top, middle support, and two anchoring brackets.

# Titan Box Frame

The Titan T12 box frames are 48" tall and available from 24" to 72" wide. The frame allows for use of vertical space above work surface. Box frames are easily bolted to counter top. Shelving and wall can be used with Titan cores with uprights. Slotted uprights with 1" increments allow for height adjustment cabinets or shelving. T9 unit is designed for use when the casework is against the wall. This unit has the same specifications as the T12 Box Frame above except it is 9" deep. This unit is a single sided unit. Side panels to cover the space between uprights can be ordered separately and services can be run through them. All the components are ordered separately.

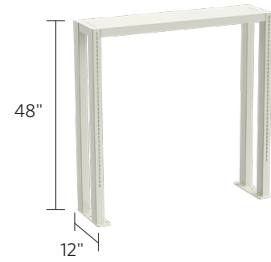

## TITAN BOX FRAME ASSEMBLY



# Titan Box Frame

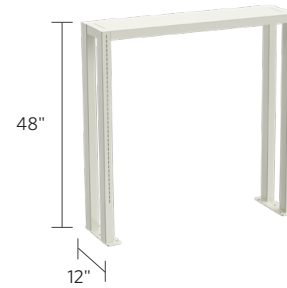
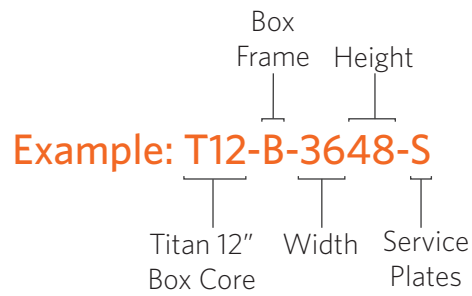

## 12" DEPTH BOX FRAME COUNTER MOUNT



Width	Item Number
24"	T12-B-2448
30"	T12-B-3048
36"	T12-B-3648
42"	T12-B-4248
48"	T12-B-4848
54"	T12-B-5448
60"	T12-B-6048
66"	T12-B-6648
72"	T12-B-7248

## 9" DEPTH WALL BOX FRAME COUNTER MOUNT



Width	Item Number
24"	T9-B-2448
30"	T9-B-3048
36"	T9-B-3648
42"	T9-B-4248
48"	T9-B-4848
54"	T9-B-5448
60"	T9-B-6048
66"	T9-B-6648
72"	T9-B-7248

## 3" DEPTH BOX FRAME COUNTER MOUNT



Width	Item Number
24"	T3-B-2448
30"	T3-B-3048
36"	T3-B-3648
42"	T3-B-4248
48"	T3-B-4848
54"	T3-B-5448
60"	T3-B-6048
66"	T3-B-6648
72"	T3-B-7248

# Titan Box Frame Shared

Allows use of vertical space above work surface when needed. Box frames are easily bolted to counter top. Slotted uprights for shelving with 1" increments. Side panels to cover the space between uprights can be ordered separately for services to be run through them. Both the single uprights and cross members must be ordered at the same time to create a complete Titan Shared Upright Shelf kits must be ordered separately.

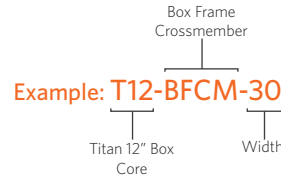
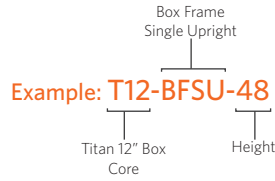
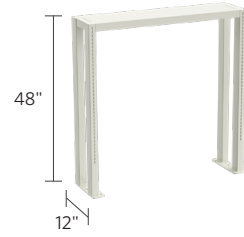

## 12" SHARED BOX FRAME

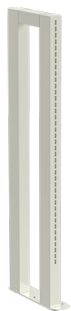

Height	Item Number
48"	T12-BFSU-48

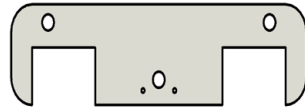

Width	Item Number
24"	T12-BFCM-24
30"	T12-BFCM-30
36"	T12-BFCM-36
42"	T12-BFCM-42
48"	T12-BFCM-48
54"	T12-BFCM-54
60"	T12-BFCM-60
66"	T12-BFCM-66
72"	T12-BFCM-72

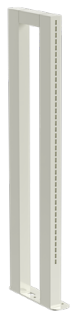

Height	Item Number
48"	T12-BFSU-48-S

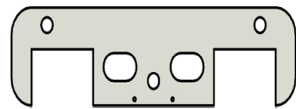

## 3" SHARED BOX FRAME



Width	Item Number
24"	T3-BFCM-24
30"	T3-BFCM-30
36"	T3-BFCM-36
42"	T3-BFCM-42
48"	T3-BFCM-48
54"	T3-BFCM-54
60"	T3-BFCM-60
66"	T3-BFCM-66
72"	T3-BFCM-72

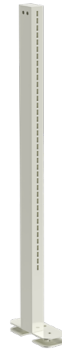

Height	Item Number
48"	T3-BFSU-48



# Titan Side Removable Panels

Optional side panels are 18 gauge CRS Side panels to cover the space between uprights can be ordered separately and services can be run through them.

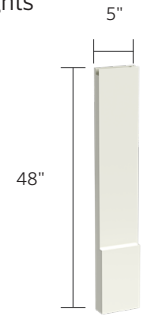
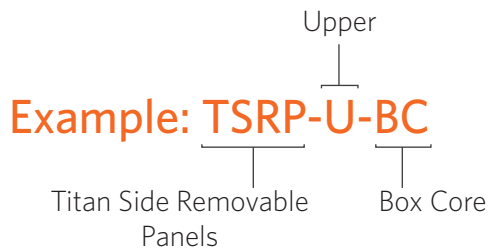

## UPPER PANELS

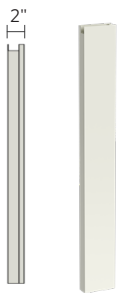

Item Number
TSRP-U-BC
Use With
T12
T9

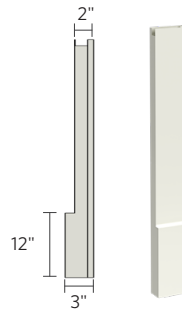

Item Number
TSRP-U-BC-12LP
Use With
T12
T9

Recommended when services needed.



Item Number
T6-LPA-84U
Use With
T6



Item Number
T6-UPA-84U
Use With
T6

## LOWER PANELS



Item Number
TSRP-L
Use With
T12
T9



Item Number
TSRP-M
Use With
T12
T9

## BOX FRAME PANELS

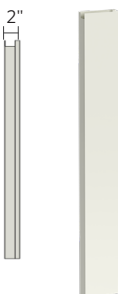

Item Number
TSRP-BF-48
Use With
Box Frame

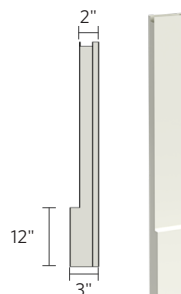

Item Number
TSRP-BF-48-12LP
Use With
Box Frame

Recommended when services needed.

# Titan Shelf Kit

Titan shelving come in four different styles. There are Bookend (B), Inverted (U), Seismic Rod (SR), and Inner (I). The shelves will fit in any Titan Core, Titan Box Frames, Titan Work Benches, and Titan Mobile Carts. Kit widths should match the width of the unit it is paired with. Standard depth kits Shelves are the same depth as brackets and set with flush mount uprights. Extended depth kits shelves are deeper than the brackets and extended to the back. We offer 1", 3", and 6" extended shelf kits.

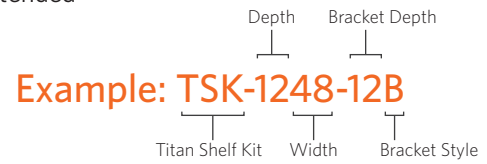

## STANDARD DEPTH KITS

When ordering FLIPs for TSK, the part number must be 2" less width than the given Shelf Kit.

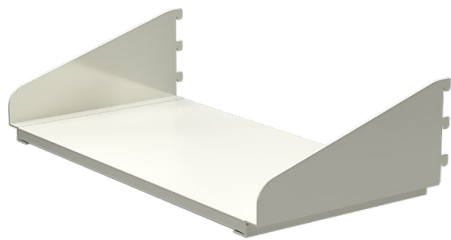

Width	12" Brackets	14" Brackets	16" Brackets	18" Brackets
24"	TSK-1224-12B	TSK-1424-14B	TSK-1624-16B	TSK-1824-18B
30"	TSK-1230-12B	TSK-1430-14B	TSK-1630-16B	TSK-1830-18B
36"	TSK-1236-12B	TSK-1436-14B	TSK-1636-16B	TSK-1836-18B
42"	TSK-1242-12B	TSK-1442-14B	TSK-1642-16B	TSK-1842-18B
48"	TSK-1248-12B	TSK-1448-14B	TSK-1648-16B	TSK-1848-18B
54"	TSK-1254-12B	TSK-1454-14B	TSK-1654-16B	TSK-1854-18B
60"	TSK-1260-12B	TSK-1460-14B	TSK-1660-16B	TSK-1860-18B
66"	TSK-1266-12B	TSK-1466-14B	TSK-1666-16B	TSK-1866-18B
72"	TSK-1272-12B	TSK-1472-14B	TSK-1672-16B	TSK-1872-18B



Width	12" Brackets	14" Brackets	16" Brackets	18" Brackets
24"	TSK-1224-12SR	TSK-1424-14SR	TSK-1624-16SR	TSK-1824-18SR
30"	TSK-1230-12SR	TSK-1430-14SR	TSK-1630-16SR	TSK-1830-18SR
36"	TSK-1236-12SR	TSK-1436-14SR	TSK-1636-16SR	TSK-1836-18SR
42"	TSK-1242-12SR	TSK-1442-14SR	TSK-1642-16SR	TSK-1842-18SR
48"	TSK-1248-12SR	TSK-1448-14SR	TSK-1648-16SR	TSK-1848-18SR
54"	TSK-1254-12SR	TSK-1454-14SR	TSK-1654-16SR	TSK-1854-18SR
60"	TSK-1260-12SR	TSK-1460-14SR	TSK-1660-16SR	TSK-1860-18SR
66"	TSK-1266-12SR	TSK-1466-14SR	TSK-1666-16SR	TSK-1866-18SR
72"	TSK-1272-12SR	TSK-1472-14SR	TSK-1672-16SR	TSK-1872-18SR

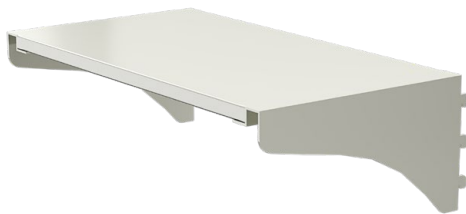

Width	12" Brackets	14" Brackets	16" Brackets	18" Brackets
24"	TSK-1224-12U	TSK-1424-14U	TSK-1624-16U	TSK-1824-18U
30"	TSK-1230-12U	TSK-1430-14U	TSK-1630-16U	TSK-1830-18U
36"	TSK-1236-12U	TSK-1436-14U	TSK-1636-16U	TSK-1836-18U
42"	TSK-1242-12U	TSK-1442-14U	TSK-1642-16U	TSK-1842-18U
48"	TSK-1248-12U	TSK-1448-14U	TSK-1648-16U	TSK-1848-18U
54"	TSK-1254-12U	TSK-1454-14U	TSK-1654-16U	TSK-1854-18U
60"	TSK-1260-12U	TSK-1460-14U	TSK-1660-16U	TSK-1860-18U
66"	TSK-1266-12U	TSK-1466-14U	TSK-1666-16U	TSK-1866-18U
72"	TSK-1272-12U	TSK-1472-14U	TSK-1672-16U	TSK-1872-18U

# Titan Shelf Kits

Titan extended shelf kits come in four different styles. There are Bookend (B), Inverted (U), and Seismic Rod (SR). The brackets will fit in any Titan Core, Titan Box Frame, Titan Work Bench, and Titan Mobile Cart. Kit widths should match the width of the unit it is paired with. We offer 1", 3", and 6" extended shelf kits.

## EXTENDED DEPTH KITS

When ordering FLIPs for TSK, the part number must be 2" less width than the given Shelf Kit.

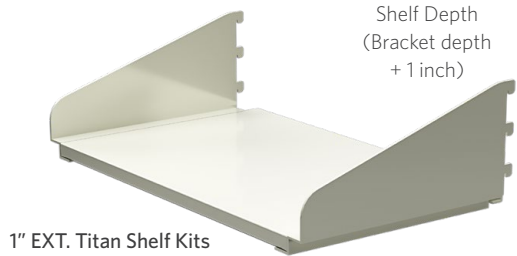

1" EXT. Titan Shelf Kits

Width	12" Brackets	14" Brackets	16" Brackets	18" Brackets
24"	TSK-1324-12B	TSK-1524-14B	TSK-1724-16B	TSK-1924-18B
30"	TSK-1330-12B	TSK-1530-14B	TSK-1730-16B	TSK-1930-18B
36"	TSK-1336-12B	TSK-1536-14B	TSK-1736-16B	TSK-1936-18B
42"	TSK-1342-12B	TSK-1542-14B	TSK-1742-16B	TSK-1942-18B
48"	TSK-1348-12B	TSK-1548-14B	TSK-1748-16B	TSK-1948-18B
54"	TSK-1354-12B	TSK-1554-14B	TSK-1754-16B	TSK-1954-18B
60"	TSK-1360-12B	TSK-1560-14B	TSK-1760-16B	TSK-1960-18B
66"	TSK-1366-12B	TSK-1566-14B	TSK-1766-16B	TSK-1966-18B
72"	TSK-1372-12B	TSK-1572-14B	TSK-1772-16B	TSK-1972-18B

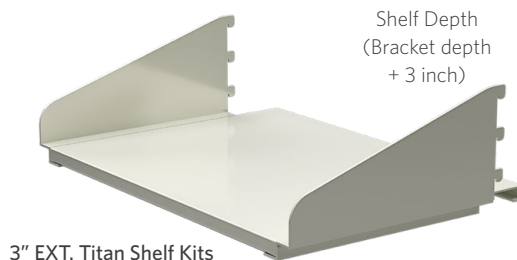

3" EXT. Titan Shelf Kits

Width	12" Brackets	14" Brackets	16" Brackets	18" Brackets
24"	TSK-1524-12B	TSK-1724-14B	TSK-1924-16B	TSK-2124-18B
30"	TSK-1530-12B	TSK-1730-14B	TSK-1930-16B	TSK-2130-18B
36"	TSK-1536-12B	TSK-1736-14B	TSK-1936-16B	TSK-2136-18B
42"	TSK-1542-12B	TSK-1742-14B	TSK-1942-16B	TSK-2142-18B
48"	TSK-1548-12B	TSK-1748-14B	TSK-1948-16B	TSK-2148-18B
54"	TSK-1554-12B	TSK-1754-14B	TSK-1954-16B	TSK-2154-18B
60"	TSK-1560-12B	TSK-1760-14B	TSK-1960-16B	TSK-2160-18B
66"	TSK-1566-12B	TSK-1766-14B	TSK-1966-16B	TSK-2166-18B
72"	TSK-1572-12B	TSK-1772-14B	TSK-1972-16B	TSK-2172-18B

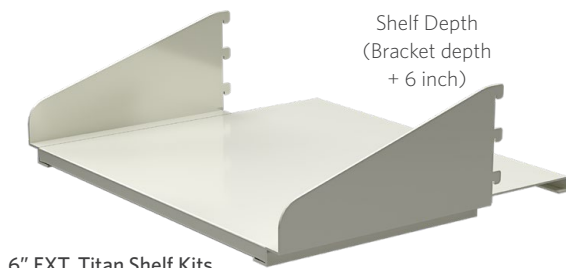

6" EXT. Titan Shelf Kits

Width	12" Brackets	14" Brackets	16" Brackets	18" Brackets
24"	TSK-1824-12B	TSK-2024-14B	TSK-2224-16B	TSK-2424-18B
30"	TSK-1830-12B	TSK-2030-14B	TSK-2230-16B	TSK-2430-18B
36"	TSK-1836-12B	TSK-2036-14B	TSK-2236-16B	TSK-2436-18B
42"	TSK-1842-12B	TSK-2042-14B	TSK-2242-16B	TSK-2442-18B
48"	TSK-1848-12B	TSK-2048-14B	TSK-2248-16B	TSK-2448-18B
54"	TSK-1854-12B	TSK-2054-14B	TSK-2254-16B	TSK-2454-18B
60"	TSK-1860-12B	TSK-2060-14B	TSK-2260-16B	TSK-2460-18B
66"	TSK-1866-12B	TSK-2066-14B	TSK-2266-16B	TSK-2466-18B
72"	TSK-1872-12B	TSK-2072-14B	TSK-2272-16B	TSK-2472-18B

# Titan Shelf Kits

Titan brackets come in three different styles. There are bookend, inverted and inner shelf designs.

## STANDARD BRACKET KITS

Includes left and right when ordered.



Width	Brackets
12"	SE-12
14"	SE-14
16"	SE-16
18"	SE-18



Width	Brackets
12"	SEU-12
14"	SEU-14
16"	SEU-16
18"	SEU-18



Width	Brackets
12"	SE-12-SR
14"	SE-14-SR
16"	SE-16-SR
18"	SE-18-SR



Width	Brackets
12"	LSE-12
14"	LSE-14
16"	LSE-16
18"	LSE-18

## INNER SHELF KITS

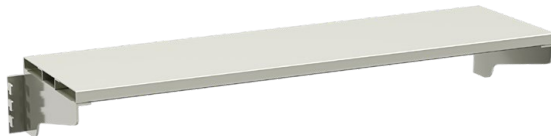

Width	For 12" BOX CORE	For 9" BOX CORE
24"	TSK-1224-12I	TSK-924-9I
30"	TSK-1230-12I	TSK-930-9I
36"	TSK-1236-12I	TSK-936-9I
42"	TSK-1242-12I	TSK-942-9I
48"	TSK-1248-12I	TSK-948-9I
54"	TSK-1254-12I	TSK-954-9I
60"	TSK-1260-12I	TSK-960-9I
66"	TSK-1266-12I	TSK-966-9I
72"	TSK-1272-12I	TSK-972-9I



1" High Shelf Lips (Fits Front or Back 1")  
Front / Back Lip

Item Number	Use With
FLIP22	24" W TSK
FLIP28	30" W TSK
FLIP34	36" W TSK
FLIP40	42" W TSK
FLIP46	48" W TSK
FLIP52	54" W TSK
FLIP58	60" W TSK



# Cantilever Table Frame

Cantilever table frames are an essential component setting a Titan configuration in your lab. The frames are constructed in 14 gauge steel, come in two different styles. Structural cantilever table and cantilever table. Both tables will support up to 800lbs loaded evenly. The structural support table frames (SCTF) attach directly to the core, allowing it to support the Island or wall cores. This setup is ideal when cores cannot be anchored to the floor. The table has a fixed height of 29" or 35". The cantilever table frames (CTF) attach directly to the bolted core and is adjustable in one inch increments. Both frames can support suspended cabinets.

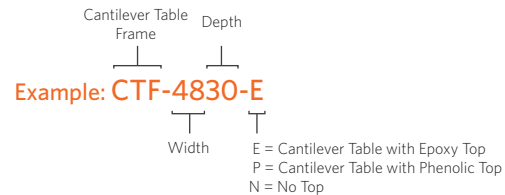
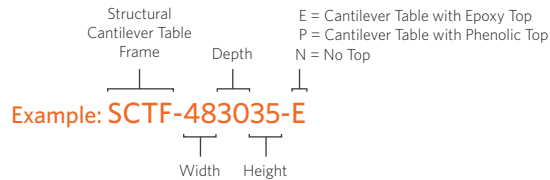
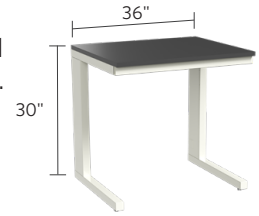

## STRUCTURAL CANTILEVER TABLE FRAME



SCTF-363035-**N** Shown

Width	Item Number	Item Number	Item Number	Item Number
24"	SCTF-242429-N	SCTF-242435-N	SCTF-243029-N	SCTF-243035-N
30"	SCTF-302429-N	SCTF-302435-N	SCTF-303029-N	SCTF-303035-N
36"	SCTF-362429-N	SCTF-362435-N	SCTF-363029-N	SCTF-363035-N
42"	SCTF-422429-N	SCTF-422435-N	SCTF-423029-N	SCTF-423035-N
48"	SCTF-482429-N	SCTF-482435-N	SCTF-483029-N	SCTF-483035-N
54"	SCTF-542429-N	SCTF-542435-N	SCTF-543029-N	SCTF-543035-N
60"	SCTF-602429-N	SCTF-602435-N	SCTF-603029-N	SCTF-603035-N
66"	SCTF-662429-N	SCTF-662435-N	SCTF-663029-N	SCTF-663035-N
72"	SCTF-722429-N	SCTF-722435-N	SCTF-723029-N	SCTF-723035-N



SCTF-363035-**E** Shown With Epoxy Top

## CANTILEVER FRAME



CTF-3630-**N** Shown

Width	Item Number	Item Number
24"	CTF-2424-N	CTF-2430-N
30"	CTF-3024-N	CTF-3030-N
36"	CTF-3624-N	CTF-3630-N
42"	CTF-4224-N	CTF-4230-N
48"	CTF-4824-N	CTF-4830-N
54"	CTF-5424-N	CTF-5430-N
60"	CTF-6024-N	CTF-6030-N
66"	CTF-6624-N	CTF-6630-N
72"	CTF-7224-N	CTF-7230-N



CTF-3630-**E** Shown With Epoxy Top

# Wall Rail System

The wall rail system is installed in applications where there may not be backing to support standards and only shelving will be installed. With a 1" profile, heights of 24", 30", 36", 42" and widths from 24"-72", this system is very flexible to change shelf widths in the future. Proper blocking required for horizontal rails. Wall shelf kit ordered separately (See page 31).

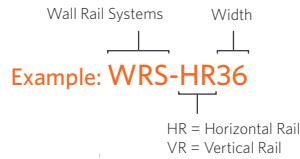
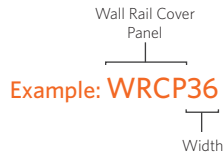
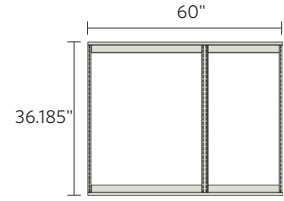

## WALL RAIL SYSTEM LOAD RATINGS

Parts	Loading Rate
Shelving with Bracket Depth 12 and 14	200lbs
Shelving with Bracket Depth 16 and 18	160lbs
Maximum Per Section	400lbs

For shelving only. If cabinets or cantilever frames are required, use our heavy duty wall rail system (page 32).

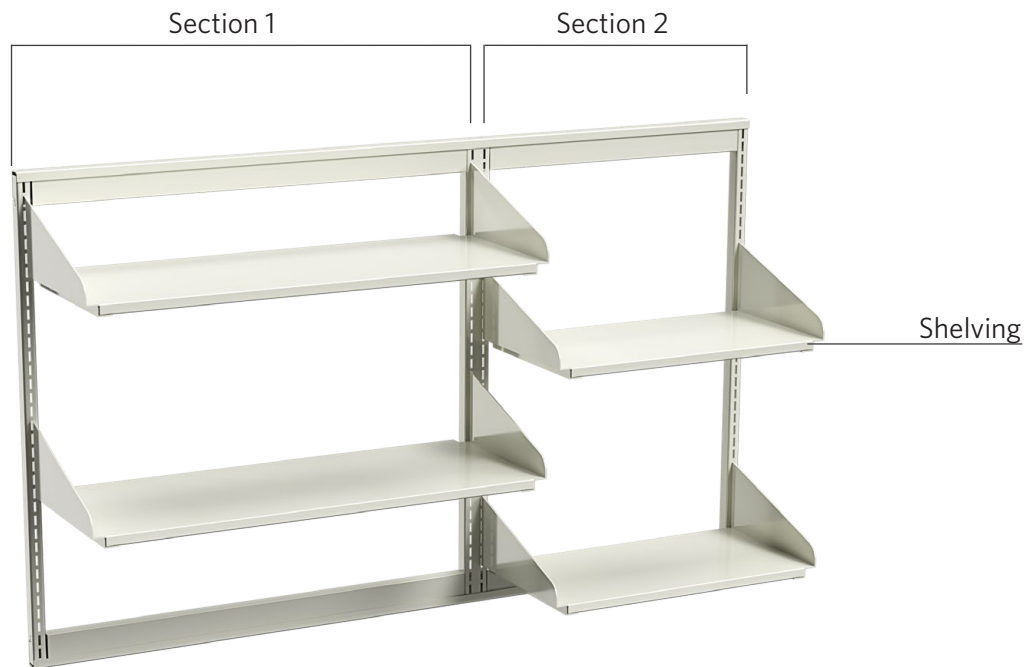

# Wall Rail System

## How To Order: By Components

- WRS-VR36 (2)
- WRS-HR60 (2)
- WRS-VRDS36 (1)
- WRCP36 (2)
- WRCP24 (2)

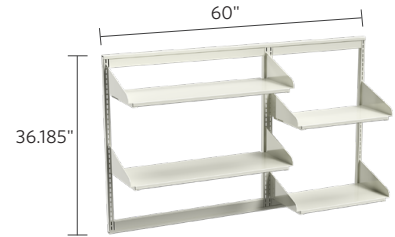
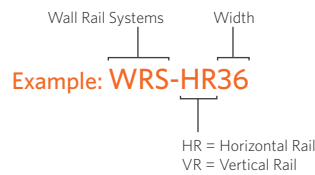
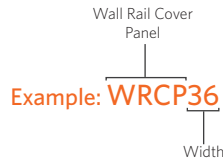

**SHELVES SHOWN**  
TWSK-1336-12B (2)  
TWSK-1224-12B (2)

## WALL RAIL SYSTEM

Cover Panel

Width	Item Number
24"	WRCP24
30"	WRCP30
36"	WRCP36
42"	WRCP42
48"	WRCP48
54"	WRCP54
60"	WRCP60
66"	WRCP66
72"	WRCP72

Horizontal Rail

Width	Item Number
24"	WRS-HR24
30"	WRS-HR30
36"	WRS-HR36
42"	WRS-HR42
48"	WRS-HR48
54"	WRS-HR54
60"	WRS-HR60
66"	WRS-HR66
72"	WRS-HR72

Vertical Rail

Height	Item Number
24"	WRS-VR24
30"	WRS-VR30
36"	WRS-VR36
42"	WRS-VR42
48"	WRS-VR48

Vertical Double Slotted Rail

Height	Item Number
24"	WRS-VRDS24
30"	WRS-VRDS30
36"	WRS-VRDS36
42"	WRS-VRDS42
48"	WRS-VRDS48

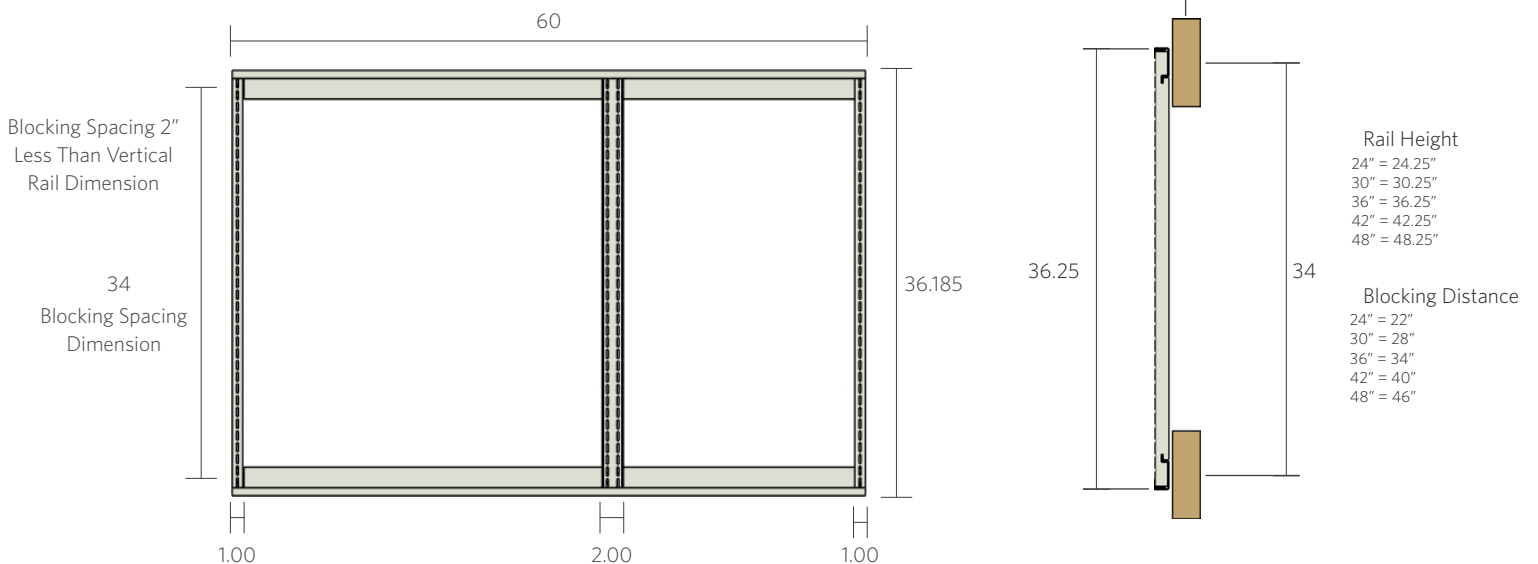

# Titan Wall Shelf Kits

\* TWSK Only use with wall rail system.

## TITAN WALL SHELF KITS

When ordering FLIPs for TWSK, the part number must be 1" less width than the given Shelf Kit.

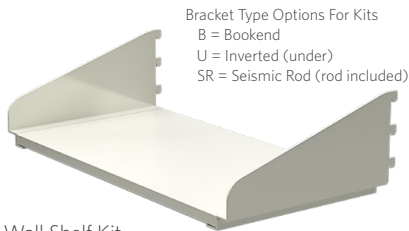

Titan Wall Shelf Kit

**TWSK-1230-12B**

Width	12" Brackets	14" Brackets	16" Brackets
24"	TWSK-1224-12B	TWSK-1424-14B	TWSK-1624-16B
30"	TWSK-1230-12B	TWSK-1430-14B	TWSK-1630-16B
36"	TWSK-1236-12B	TWSK-1436-14B	TWSK-1636-16B
42"	TWSK-1242-12B	TWSK-1442-14B	TWSK-1642-16B
48"	TWSK-1248-12B	TWSK-1448-14B	TWSK-1648-16B
54"	TWSK-1254-12B	TWSK-1454-14B	TWSK-1654-16B
60"	TWSK-1260-12B	TWSK-1460-14B	TWSK-1660-16B
66"	TWSK-1266-12B	TWSK-1466-14B	TWSK-1666-16B
72"	TWSK-1272-12B	TWSK-1472-14B	TWSK-1672-16B

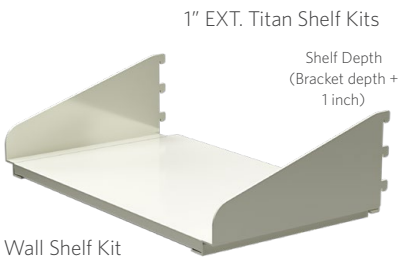

Titan Wall Shelf Kit

**TWSK-1330-12B**

Width	12" Brackets	14" Brackets	16" Brackets
24"	TWSK-1324-12B	TWSK-1524-14B	TWSK-1724-16B
30"	TWSK-1330-12B	TWSK-1530-14B	TWSK-1730-16B
36"	TWSK-1336-12B	TWSK-1536-14B	TWSK-1736-16B
42"	TWSK-1342-12B	TWSK-1542-14B	TWSK-1742-16B
48"	TWSK-1348-12B	TWSK-1548-14B	TWSK-1748-16B
54"	TWSK-1354-12B	TWSK-1554-14B	TWSK-1754-16B
60"	TWSK-1360-12B	TWSK-1560-14B	TWSK-1760-16B
66"	TWSK-1366-12B	TWSK-1566-14B	TWSK-1766-16B
72"	TWSK-1372-12B	TWSK-1572-14B	TWSK-1772-16B



Titan Wall Shelf Kit

**TWSK-TOP-1230-12U**

Width	12" Brackets	14" Brackets	16" Brackets
24"	TWSK-TOP-1224-12U	TWSK-TOP-1424-14U	TWSK-TOP-1624-16U
30"	TWSK-TOP-1230-12U	TWSK-TOP-1430-14U	TWSK-TOP-1630-16U
36"	TWSK-TOP-1236-12U	TWSK-TOP-1436-14U	TWSK-TOP-1636-16U
42"	TWSK-TOP-1242-12U	TWSK-TOP-1442-14U	TWSK-TOP-1642-16U
48"	TWSK-TOP-1248-12U	TWSK-TOP-1448-14U	TWSK-TOP-1648-16U
54"	TWSK-TOP-1254-12U	TWSK-TOP-1454-14U	TWSK-TOP-1654-16U
60"	TWSK-TOP-1260-12U	TWSK-TOP-1460-14U	TWSK-TOP-1660-16U
66"	TWSK-TOP-1266-12U	TWSK-TOP-1466-14U	TWSK-TOP-1666-16U
72"	TWSK-TOP-1272-12U	TWSK-TOP-1472-14U	TWSK-TOP-1672-16U

1" High Shelf Lips (Fits Fronts or Back 1")



**FLIP35**

Item Number	Use With
FLIP23	24" W TWSK
FLIP29	30" W TWSK
FLIP35	36" W TWSK
FLIP41	42" W TWSK
FLIP47	48" W TWSK
FLIP53	54" W TWSK
FLIP59	60" W TWSK

# Wall Standards

Wall standards are the least expensive way to install shelving for a wall. It requires full proper blocking along the whole standard to assure they are able to hold the weight on the shelves.

Mechanical Tub  
Standard

Example: **MTS1136**

Height

## WALL STANDARDS



Height	Item Number
24"	MTS1124
30"	MTS1130
36"	MTS1136
42"	MTS1142
48"	MTS1148
72"	MTS1172

\*Standards accommodate two brackets

## WALL STANDARD SHELF KITS

When ordering FLIPs for WSK, the part number will be the **SAME** width as the Shelf Kit.

Bracket Type Options For Kits  
 B = Bookend  
 U = Inverted (under)  
 SR = Seismic Rod (rod included)

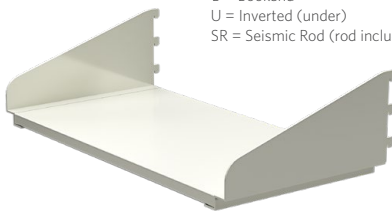

**WSK-1230-12B**

Width	12" Brackets	14" Brackets	16" Brackets
24"	WSK-1224-12B	WSK-1424-14B	WSK-1624-16B
30"	WSK-1230-12B	WSK-1430-14B	WSK-1630-16B
36"	WSK-1236-12B	WSK-1436-14B	WSK-1636-16B
42"	WSK-1242-12B	WSK-1442-14B	WSK-1642-16B
48"	WSK-1248-12B	WSK-1448-14B	WSK-1648-16B
54"	WSK-1254-12B	WSK-1454-14B	WSK-1654-16B
60"	WSK-1260-12B	WSK-1460-14B	WSK-1660-16B
66"	WSK-1266-12B	WSK-1466-14B	WSK-1666-16B
72"	WSK-1272-12B	WSK-1472-14B	WSK-1672-16B

\* Only use with wall standards.

1" EXT. Titan Shelf Kits

Shelf Depth  
(Bracket depth + 1 inch)

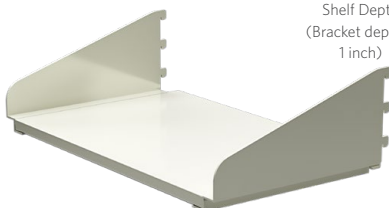

**WSK-1330-12B**

Width	12" Brackets	14" Brackets	16" Brackets
24"	WSK-1324-12B	WSK-1524-14B	WSK-1724-16B
30"	WSK-1330-12B	WSK-1530-14B	WSK-1730-16B
36"	WSK-1336-12B	WSK-1536-14B	WSK-1736-16B
42"	WSK-1342-12B	WSK-1542-14B	WSK-1742-16B
48"	WSK-1348-12B	WSK-1548-14B	WSK-1748-16B
54"	WSK-1354-12B	WSK-1554-14B	WSK-1754-16B
60"	WSK-1360-12B	WSK-1560-14B	WSK-1760-16B
66"	WSK-1366-12B	WSK-1566-14B	WSK-1766-16B
72"	WSK-1372-12B	WSK-1572-14B	WSK-1772-16B

\* Only use with wall standards.

# Heavy Duty Wall Rails

Wall Rail HD: Heavy Duty Rails- capability to support table frames (with optional suspended cabinets) Profile: 1" deep, 2" wide vertical rails. Available heights: 24", 30", 36", 42", 48" and 78". Available widths: from 24", 30", 36", 42", 48", 54", 60", 66", 72". Proper blocking needed for horizontal rails, extra blocking required for 78" high rails. Components to order: -Horizontal channels (2)-Vertical Upright - Single Slotted (2 per section)-Cover Panels Gauges

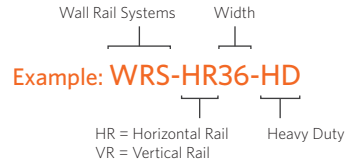
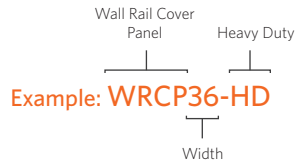

## HEAVY DUTY WALL RAIL SYSTEM LOAD RATINGS

Parts	Loading Rate
Shelving with Bracket Depth 12 and 14	200lbs
Shelving with Bracket Depth 16 and 18	160lbs
Cantilevered Table Frame	400lbs
Maximum Per Section	800lbs

### How To Order: By Components

- WRS-VRA78-HD (4)      **SHELVES SHOWN**  
TSK-1336-12B
- WRS-HR72-HD (2)
- TABLES SHOWN**  
CTF-3624-N
- WRCP36-HD (4)

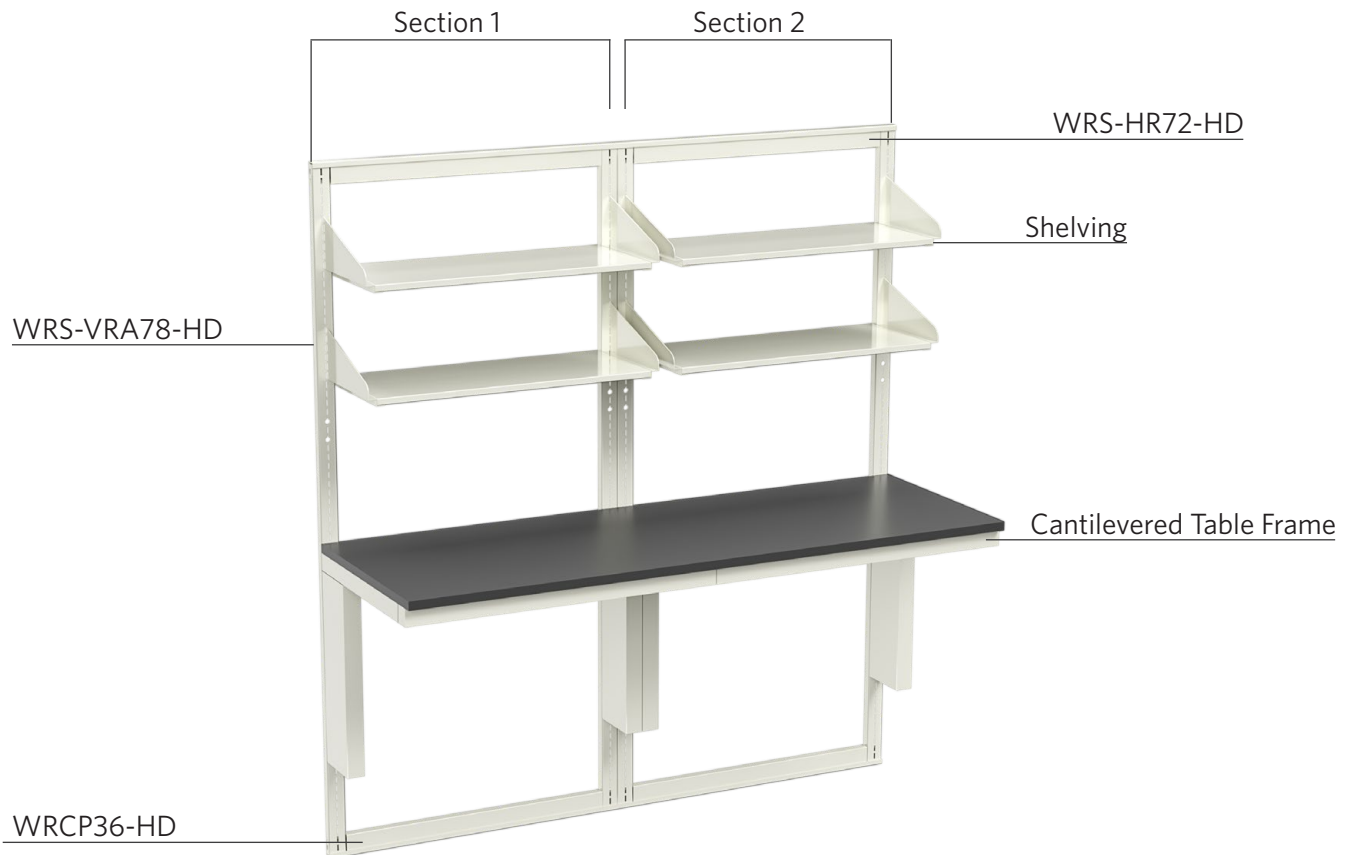

# Heavy Duty Wall Rails

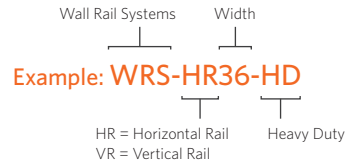
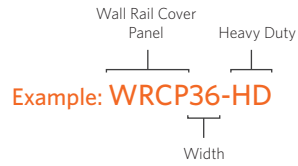

## HEAVY DUTY WALL RAIL SYSTEM

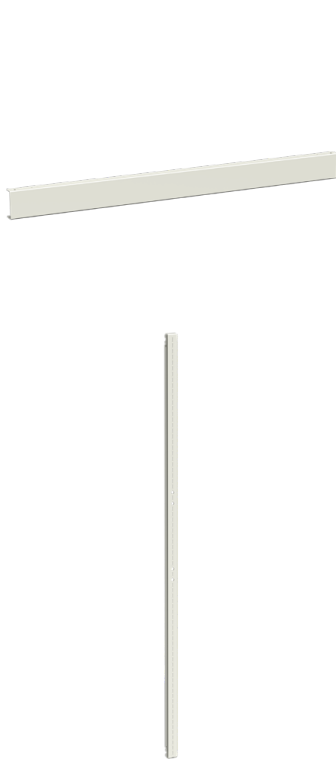

Width	Item Number
24"	WRCP24-HD
30"	WRCP30-HD
36"	WRCP36-HD
42"	WRCP42-HD
48"	WRCP48-HD
54"	WRCP54-HD
60"	WRCP60-HD
66"	WRCP66-HD
72"	WRCP72-HD

Width	Item Number
24"	WRS-HR24-HD
30"	WRS-HR30-HD
36"	WRS-HR36-HD
42"	WRS-HR42-HD
48"	WRS-HR48-HD
54"	WRS-HR54-HD
60"	WRS-HR60-HD
66"	WRS-HR66-HD
72"	WRS-HR72-HD

Height	Item Number
78"	WRS-VRA78-HD

Height	Item Number
24"	WRS-VR24-HD
30"	WRS-VR30-HD
36"	WRS-VR36-HD
42"	WRS-VR42-HD
48"	WRS-VR48-HD

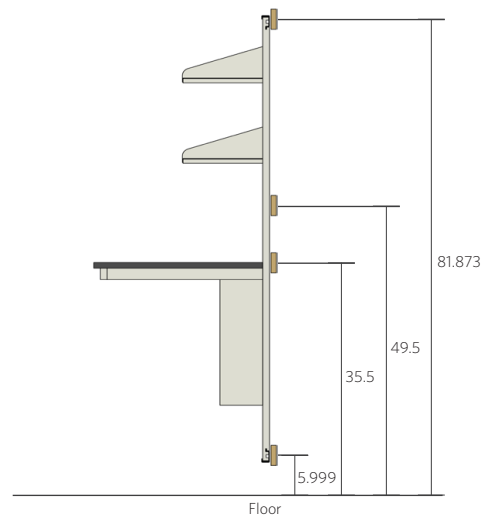
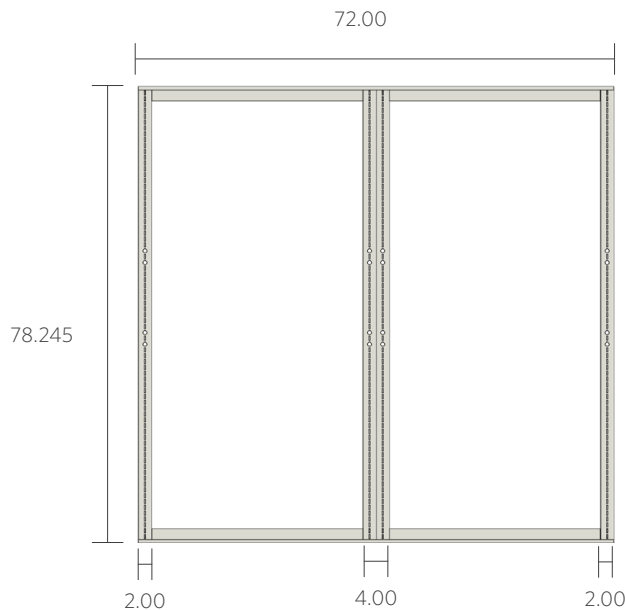



# Heavy Duty Shelf Kits

Parts	Loading Rate
Shelving with Bracket Depth 12 and 14	200lbs
Shelving with Bracket Depth 16 and 18	160lbs

## HEAVY DUTY SHELF KITS

When ordering FLIPs for TSK, the part number must be 2" less width than the given Shelf Kit.

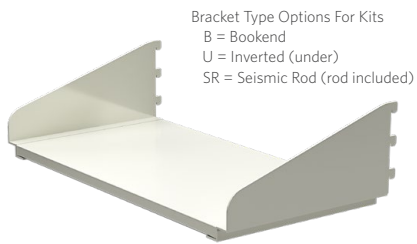

**TSK-1230-12B**  
Titan Wall Shelf Kit

Width	12" Brackets	14" Brackets	16" Brackets	18" Brackets
24"	TSK-1224-12B	TSK-1424-14B	TSK-1624-16B	TSK-1824-18B
30"	TSK-1230-12B	TSK-1430-14B	TSK-1630-16B	TSK-1830-18B
36"	TSK-1236-12B	TSK-1436-14B	TSK-1636-16B	TSK-1836-18B
42"	TSK-1242-12B	TSK-1442-14B	TSK-1642-16B	TSK-1842-18B
48"	TSK-1248-12B	TSK-1448-14B	TSK-1648-16B	TSK-1848-18B
54"	TSK-1254-12B	TSK-1454-14B	TSK-1654-16B	TSK-1854-18B
60"	TSK-1260-12B	TSK-1460-14B	TSK-1660-16B	TSK-1860-18B
66"	TSK-1266-12B	TSK-1466-14B	TSK-1666-16B	TSK-1866-18B
72"	TSK-1272-12B	TSK-1472-14B	TSK-1672-16B	TSK-1872-18B

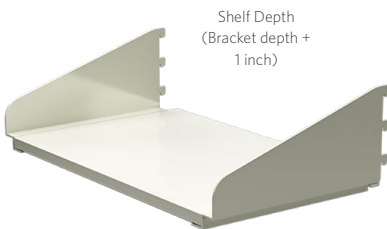

1" EXT. Titan Shelf Kits

**TSK-1330-12B**  
Titan Wall Shelf Kit

Width	12" Brackets	14" Brackets	16" Brackets	18" Brackets
24"	TSK-1324-12B	TSK-1524-14B	TSK-1724-16B	TSK-1924-18B
30"	TSK-1330-12B	TSK-1530-14B	TSK-1730-16B	TSK-1930-18B
36"	TSK-1336-12B	TSK-1536-14B	TSK-1736-16B	TSK-1936-18B
42"	TSK-1342-12B	TSK-1542-14B	TSK-1742-16B	TSK-1942-18B
48"	TSK-1348-12B	TSK-1548-14B	TSK-1748-16B	TSK-1948-18B
54"	TSK-1354-12B	TSK-1554-14B	TSK-1754-16B	TSK-1954-18B
60"	TSK-1360-12B	TSK-1560-14B	TSK-1760-16B	TSK-1960-18B
66"	TSK-1366-12B	TSK-1566-14B	TSK-1766-16B	TSK-1966-18B
72"	TSK-1372-12B	TSK-1572-14B	TSK-1772-16B	TSK-1972-18B



**FLIP35** FRONT / BACK LIP

1" High Shelf Lips (Fits Fronts or Back 1")

Item Number	Use With
FLIP22	24" W TWSK
FLIP28	30" W TWSK
FLIP34	36" W TWSK
FLIP40	42" W TWSK
FLIP46	48" W TWSK
FLIP52	54" W TWSK
FLIP58	60" W TWSK

# Titan Mobile Carts

Titan Cart features fully welded cart base. Uprights are bolted into the base. Structural vertical support for the tables, cabinets (suspended & wall versions) and shelving. Frames can be ganged side by side or back to back. Cantilever tables offer adjustable height availability. Equipped with 700 lbs locking casters. Levelers and a 750 lbs leveling caster are an option. Sizes Cores come in 2 standard heights: 78" and 36" high units. Widths come in 36", 48", 60", and 72". Depth is 30" Max Weight load Breakdown: Shelves 200lbs each (600lbs max), Table Frame can hold 800lbs, Bottom Shelf hold 400lbs. Mobile Cart maximum weight load 1800lbs.



## MOBILE CART LOAD RATINGS

Parts	Loading Rate
Shelving	200lbs
Cantilevered Table Work Frame	800lbs
Bottom Shelf Assembly	400lbs
Total Cart Assembly	1,600lbs



# Titan Mobile Carts

C = Casters Only  
 L = Leveling Feet Only  
 CL = Casters & Leveling Feet  
 H = 550lb leveling Casters  
 X = 1100lb leveling Casters

Titan Mobile Cart  
 Depth  
 Width Height Modesty Panel

**Example: TMC-483036-CL-MP-E**

E = Cantilever Table with Epoxy Top  
 P = Cantilever Table with Phenolic Top  
 N = No Top



TMC-363036-CL-E Shown

## MOBILE CARTS



Width	Item Number
36"	TMC-363036-CL-N
42"	TMC-423036-CL-N
48"	TMC-483036-CL-N
60"	TMC-603036-CL-N
72"	TMC-723036-CL-N



Width	Item Number
36"	TMC-363036-CL-MP-N
42"	TMC-423036-CL-MP-N
48"	TMC-483036-CL-MP-N
60"	TMC-603036-CL-MP-N
72"	TMC-723036-CL-MP-N

(Model shown with modesty panel)



Width	Item Number
36"	TMC-363078-CL-N
42"	TMC-423078-CL-N
48"	TMC-483078-CL-N
60"	TMC-603078-CL-N
72"	TMC-723078-CL-N



Width	Item Number
36"	TMC-363078-CL-MP-N
42"	TMC-423078-CL-MP-N
48"	TMC-483078-CL-MP-N
60"	TMC-603078-CL-MP-N
72"	TMC-723078-CL-MP-N

(Model shown with modesty panel)

# Titan Mobile Cart Components

All TSK shelves will work with this unit. Shown on page 24.

## MOBILE CART - SHELVES & WORK SURFACES

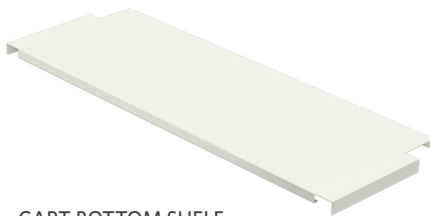

CART BOTTOM SHELF

Width	Item Number (Depth 30)	Item Number (Depth 36)
36"	TMC-BSA-3630	TMC-BSA-3636
42"	TMC-BSA-4230	TMC-BSA-4236
48"	TMC-BSA-4830	TMC-BSA-4836
60"	TMC-BSA-6030	TMC-BSA-6036
72"	TMC-BSA-7230	TMC-BSA-7236

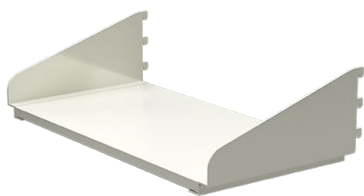

TITAN SHELF KITS  
See Titan Shelf Kits on pages 24-26 for more options.

Width	12" Brackets	14" Brackets	16" Brackets	18" Brackets
24"	TSK-1224-12B	TSK-1424-14B	TSK-1624-16B	TSK-1824-18B
30"	TSK-1230-12B	TSK-1430-14B	TSK-1630-16B	TSK-1830-18B
36"	TSK-1236-12B	TSK-1436-14B	TSK-1636-16B	TSK-1836-18B
42"	TSK-1242-12B	TSK-1442-14B	TSK-1642-16B	TSK-1842-18B
48"	TSK-1248-12B	TSK-1448-14B	TSK-1648-16B	TSK-1848-18B
54"	TSK-1254-12B	TSK-1454-14B	TSK-1654-16B	TSK-1854-18B
60"	TSK-1260-12B	TSK-1460-14B	TSK-1660-16B	TSK-1860-18B
66"	TSK-1266-12B	TSK-1466-14B	TSK-1666-16B	TSK-1866-18B
72"	TSK-1272-12B	TSK-1472-14B	TSK-1672-16B	TSK-1872-18B

# Heavy Duty Mobile Carts

Heavy Duty features fully welded cart base. Uprights are bolted into the base. Structural vertical support for the tables, cabinets (suspended & wall versions) and shelving. Cantilever tables offer adjustable height availability. Equipped with 700 lbs locking casters. Levelers and a 1100 lbs leveling caster are an option. Sizes Cores come in 2 standard heights: 78" and 36" high units. Widths come in 36", 48", 60", and 72". Depth is 30". Max Weight load Breakdown: Shelves 600lbs each (1200lbs max), Table Frame 1000lbs, Bottom Shelf 600lbs. Mobile Cart maximum weight load 2600lbs.



## HEAVY DUTY MOBILE CART LOAD RATINGS

Parts	Loading Rate
HD Shelving	600lbs
HD Table Frame	1000lbs
HD Lower Shelf	600lbs
Total Cart Assembly	2,600lbs



# Heavy Duty Mobile Carts

Heavy Duty features fully welded cart base. Uprights are bolted into the base. Structural vertical support for the tables, cabinets (suspended & wall versions) and shelving. Frames can be ganged side by side or back to back. Cantilever tables offer adjustable height availability. Equipped with 700 lbs locking casters. Levelers and a 1100 lbs leveling caster are an option. Sizes Cores come in 2 standard heights: 78" and 36" high units. Widths come in 36", 48", 60", and 72". Depth is 30". Max Weight load Breakdown: Shelves 600lbs each (1200lbs max), Table Frame 1000lbs, Bottom Shelf 600lbs. Mobile Cart maximum weight load 2600lbs.



Heavy Duty Mobile Cart

Depth

Width

Height

Cable Management

C = Casters Only  
 CL = Casters & Leveling Feet  
 H = 750lb leveling Casters

E = Cantilever Table with Epoxy Top  
 P = Cantilever Table with Phenolic Top  
 N = No Top

**Example: HDMC-483036-CL-CM-E**

## MOBILE CARTS



Width	Item Number
36"	HDMC-363036-CL-N
48"	HDMC-483036-CL-N
60"	HDMC-603036-CL-N
72"	HDMC-723036-CL-N



Width	Item Number
36"	HDMC-363078-CL-N
48"	HDMC-483078-CL-N
60"	HDMC-603078-CL-N
72"	HDMC-723078-CL-N



Width	Item Number
36"	HDMC-363078-CL-CM-N
48"	HDMC-483078-CL-CM-N
60"	HDMC-603078-CL-CM-N
72"	HDMC-723078-CL-CM-N

# Heavy Duty Mobile Cart Components

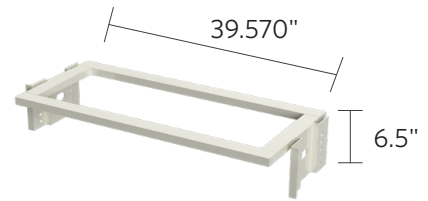
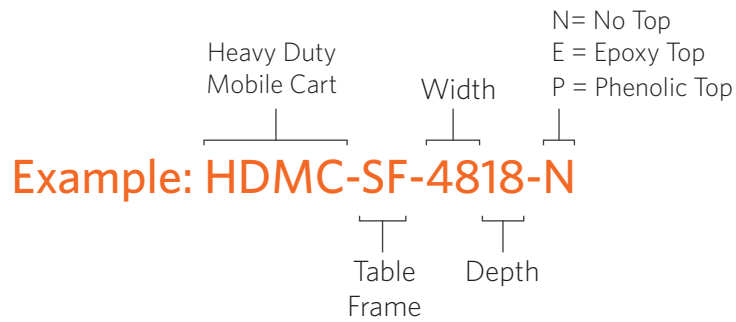

## MOBILE CART - SHELVES & WORK SURFACES

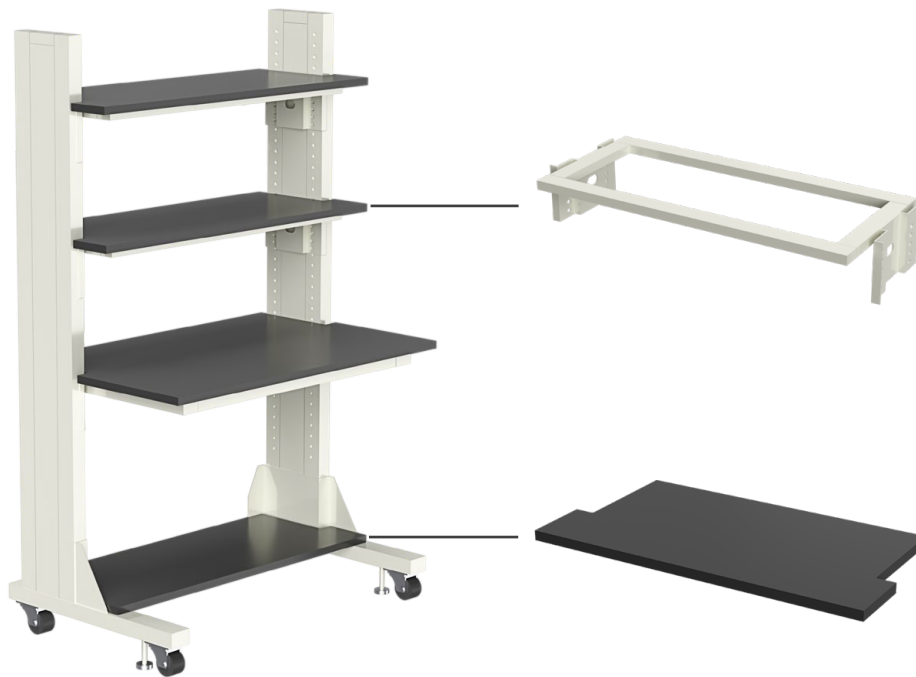

Width	Item Number
36"	HDMC-SF-3618-N
48"	HDMC-SF-4818-N
60"	HDMC-SF-6018-N
72"	HDMC-SF-7218-N

Width	Item Number
36"	HDMC-LS-3618-E
48"	HDMC-LS-4818-E
60"	HDMC-LS-6018-E
72"	HDMC-LS-7218-E



# Titan Work Bench - No Services

Titan Work Bench (TWB) gives the maximum flexibility for configuring your lab. Wall and island configurations can be readily created and easily changed as well as moved for new applications or changing space. Can be used in conjunction with suspended and mobile. Standard tables are 36" high and allow depths of 30" & 36" deep. Adjustable height units range from 30-36" high. They can be fixed or adjustable in height. In this model you can have leveling feet or casters installed. The table will support up to 1,000lbs. Order WB shelving separately. Shelf brackets are adjustable in 1" increments to allow for multiple configurations. Standard shelves are 12" or 16" deep.

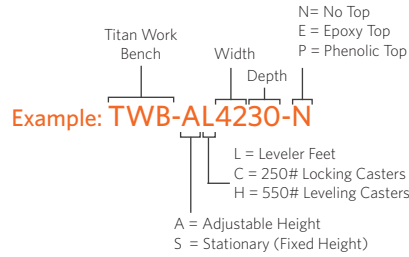

## TITAN WORK BENCH (NO SERVICES)



Width	Item Number
30"	TWB-AL3030-E
36"	TWB-AL3630-E
42"	TWB-AL4230-E
48"	TWB-AL4830-E
54"	TWB-AL5430-E
60"	TWB-AL6030-E
66"	TWB-AL6630-E
72"	TWB-AL7230-E

### LOWER SHELF

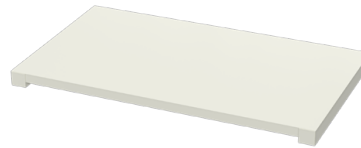

Width	Item Number
30"	TWBSHELF-3030
36"	TWBSHELF-3630
42"	TWBSHELF-4230
48"	TWBSHELF-4830
54"	TWBSHELF-5430
60"	TWBSHELF-6030
66"	TWBSHELF-6630
72"	TWBSHELF-7230

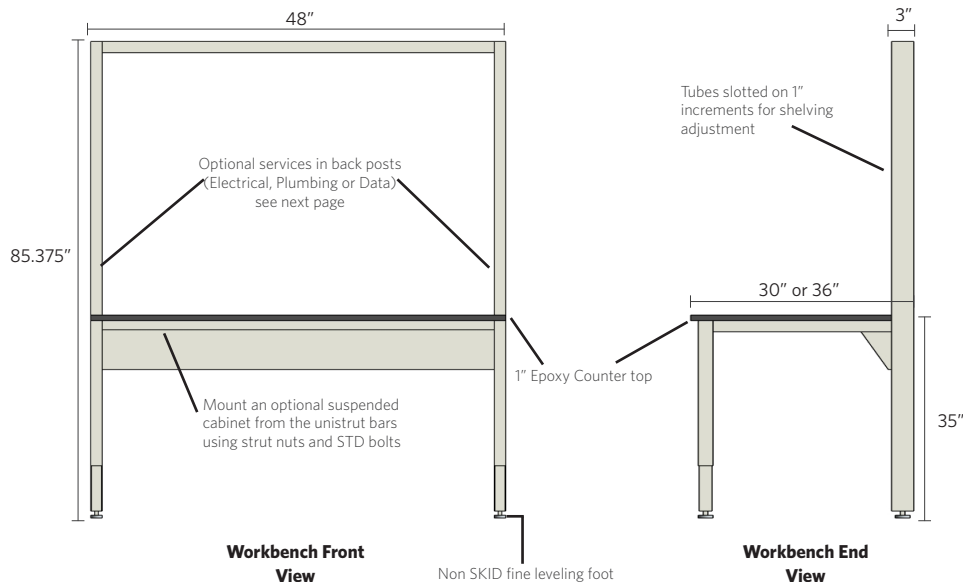

# Titan Work Bench - With Services

Titan Work Bench (TWB) gives the maximum flexibility for configuring your lab. Wall and island configurations can be readily created and easily changed as well as moved for new applications or changing space. Can be used in conjunction with suspended and mobile. Standard tables are 36" high and 30" deep. Adjustable height units range from 30-36" high. They can be fixed or adjustable in height. In this model you can have leveling feet or casters installed. The table will support up to 1,000lbs. Order WB shelving separately. Shelf brackets are adjustable in 1" increments to allow for multiple configurations. Standard shelves are 12" or 16" deep.

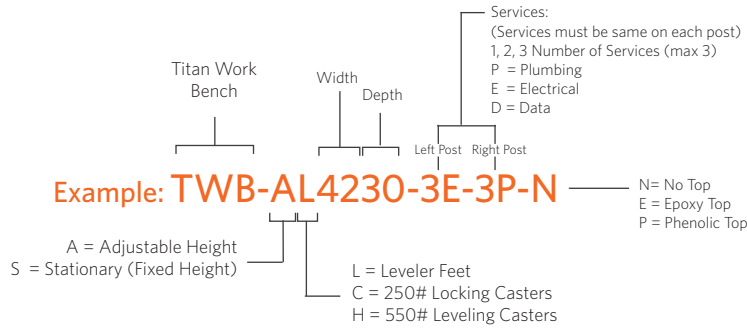

## TITAN WORK BENCH (WITH SERVICES)



Width	Item Number
30"	TWB-AL3030-3E-3P-E
36"	TWB-AL3630-3E-3P-E
42"	TWB-AL4230-3E-3P-E
48"	TWB-AL4830-3E-3P-E
54"	TWB-AL5430-3E-3P-E
60"	TWB-AL6030-3E-3P-E
66"	TWB-AL6630-3E-3P-E
72"	TWB-AL7230-3E-3P-E

We can provide one service per post:  
Plumbing: up to 3 lines  
Electric: up to 3 GFI's  
Data: 2 or 4 data ports

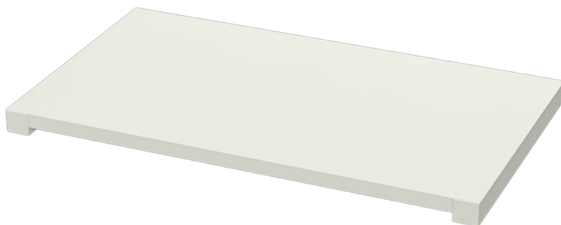

Width	Item Number
30"	TWBSHELF-3030
36"	TWBSHELF-3630
42"	TWBSHELF-4230
48"	TWBSHELF-4830
54"	TWBSHELF-5430
60"	TWBSHELF-6030
66"	TWBSHELF-6630
72"	TWBSHELF-7230

TWB Bottom Shelf only available if stationary

# Titan Work Bench - Double-Sided

Titan Work Bench (TWB) gives the maximum flexibility for configuring your lab. Wall and island configurations can be readily created and easily changed as well as moved for new applications or changing space. Can be used in conjunction with suspended and mobile. Standard tables are 36" high and 30" deep. Adjustable height units range from 30–36" high. They can be fixed or adjustable in height. In this model you can have leveling feet or casters installed. The table will support up to 1,000lbs. Order WB shelving separately. Shelf brackets are adjustable in 1" increments to allow for multiple configurations. Standard shelves are 12" or 16" deep.

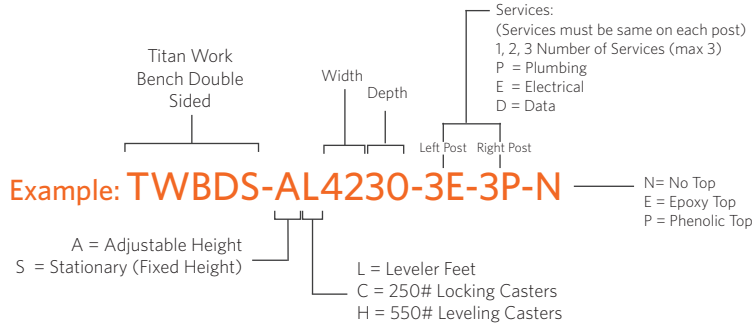

## TITAN WORK BENCH (DOUBLE-SIDED)



Width	Item Number
30"	TWBDS-AL3030-3E-3P-E
36"	TWBDS-AL3630-3E-3P-E
42"	TWBDS-AL4230-3E-3P-E
48"	TWBDS-AL4830-3E-3P-E
54"	TWBDS-AL5430-3E-3P-E
60"	TWBDS-AL6030-3E-3P-E
66"	TWBDS-AL6630-3E-3P-E
72"	TWBDS-AL7230-3E-3P-E

We can provide one service per post:  
Plumbing: up to 3 lines  
Electric: up to 3 GFI's  
Data: 2 or 4 data ports

# Table Frame

Table Frames (TF) are available in standard depths of 30" and 36". They can be fixed or adjustable in height. Many sizes are available. As standard, this 1000 lb. capacity table has strut installed for future suspended cabinet installation. Table Frames height adjustments range between 30" to 38".

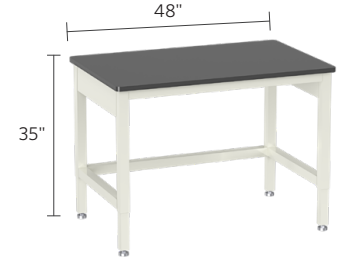

Table Frame Width Depth

**Example: TF-AL4230-N**

- N = No Top
- E = Epoxy Top
- P = Phenolic Top
- L = Leveler Feet
- C = 250# Locking Casters
- H = 550# Leveling Casters
- A = Adjustable Height
- S = Stationary (Fixed Height)

## TABLE FRAME



Width	Item Number
30"	TF-AL3030-E
36"	TF-AL3630-E
42"	TF-AL4230-E
48"	TF-AL4830-E
54"	TF-AL5430-E
60"	TF-AL6030-E
66"	TF-AL6630-E
72"	TF-AL7230-E

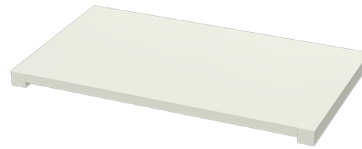

Width	Item Number
30"	TFSHELF-3030
36"	TFSHELF-3630
42"	TFSHELF-4230
48"	TFSHELF-4830
54"	TFSHELF-5430
60"	TFSHELF-6030
66"	TFSHELF-6630
72"	TFSHELF-7230

Bottom Shelf available in both Stationary & Adjustable

**Table Frame End View**

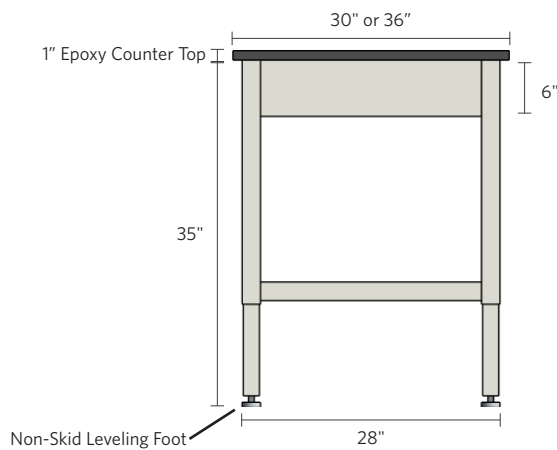

**Table Frame Front View**

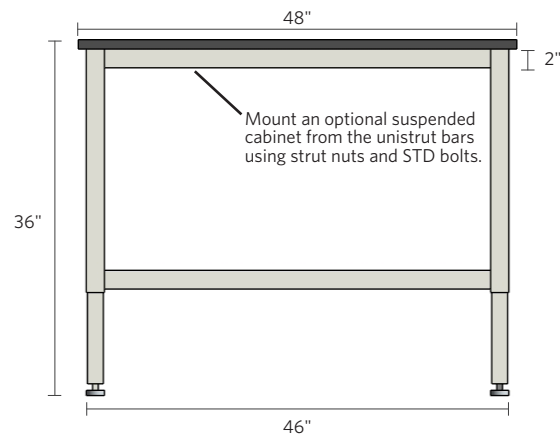

# Titan Systems Accessories

## TITAN RACEWAY

Adjustable Raceways can be used with the Titan Cores, Mobile Carts, or Work Benches. The brackets are included and the cord exits out of the bottom left, bottom right, top left, and top right.



Width	Item Number
24"	TC-24RW-2G
30"	TC-30RW-3G
36"	TC-36RW-3G
42"	TC-42RW-4G
48"	TC-48RW-4G
54"	TC-54RW-5G
60"	TC-60RW-5G
66"	TC-66RW-6G
72"	TC-72RW-6G

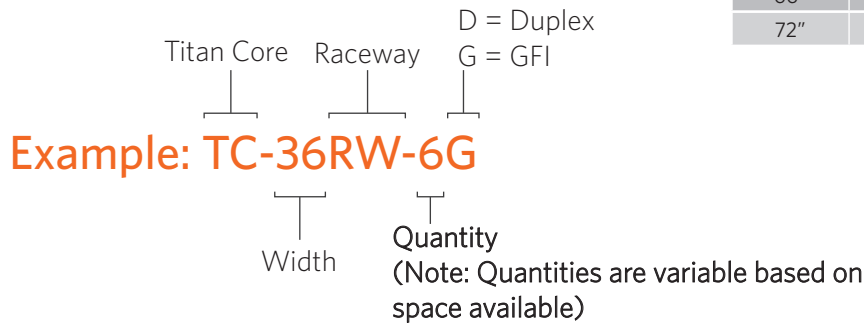

## TITAN HANGING RAIL KIT

Hanging rail kits can be used with the Titan Cores, Mobile Carts, or Work Benches. The rails are required when wall cabinets are to be suspended from cores or benches. Equal or smaller width cabinets can be hung from brackets.

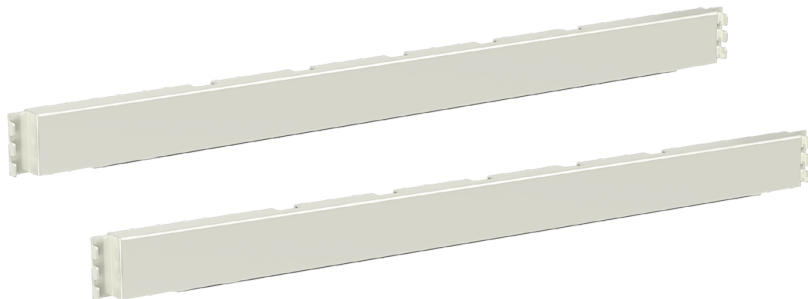

Width	Item Number
24"	THRK-24-WC
30"	THRK-30-WC
36"	THRK-36-WC
42"	THRK-42-WC
48"	THRK-48-WC
54"	THRK-54-WC
60"	THRK-60-WC
66"	THRK-66-WC
72"	THRK-72-WC

# Under Shelf Task Lights



ECON

Width	Item Number
24"	LED ECON 24IN 4000K
36"	LED ECON 36IN 4000K

## DAISY CHAIN CORD



ECON

- 12" Daisy Cord
- 24" Daisy Cord

## ECON KIT 1

- (1) 24" LED Econ Light
- (1) 24" Power Cord
- (2) Magnetic Clips
- (1) Power J-Box

## POWER CORD



ECON

- 24" 3-Prong Power Cord
- 36" 3-Prong Power Cord

## ECON KIT 2

- (2) 24" LED Econ Lights
- (1) 24" Power Cord
- (1) 12" Daisy Chain Cord
- (4) Magnetic Clips
- (1) Power J-Box

## MAGNETIC MOUNTING CLIPS



ECON

- Magnetic Clip

## ECON KIT 3

- (1) 36" LED Econ Light
- (1) 24" Power Cord
- (2) Magnetic Clips
- (1) Power J-Box

## SWITCH JUNCTION BOX



ECON

- Switch Junction Box JUN-B

## ECON KIT 4

- (2) 36" LED Econ Lights
- (1) 24" Power Cord
- (1) 12" Daisy Chain Cord
- (4) Magnetic Clips
- (1) Power J-Box

# Under Shelf Task Lights



TUCK

Width	Item Number
17"	LED TUCK 17IN 3500K
31"	LED TUCK 31IN 3500K

## DAISY CHAIN CORD

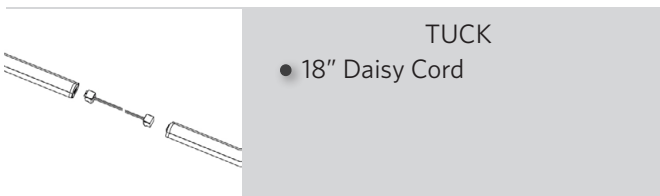

TUCK

- 18" Daisy Cord

## TUCK KIT 1

- (1) 17" LED Tuck Light
- (1) 132" Power Cord
- (2) Magnetic Clips

## POWER CORD

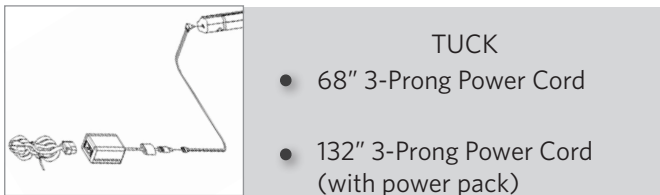

TUCK

- 68" 3-Prong Power Cord
- 132" 3-Prong Power Cord (with power pack)

## TUCK KIT 2

- (2) 17" LED Tu Lights
- (1) 132" Power Cord
- (1) 18" Daisy Chain Cord
- (4) Magnetic Clips

## MAGNETIC MOUNTING CLIPS

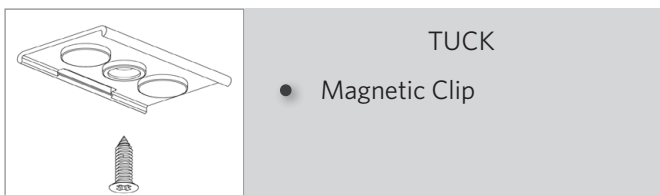

TUCK

- Magnetic Clip

## TUCK KIT 3

- (1) 31" LED Tuck Light
- (1) 132" Power Cord
- (2) Magnetic Clips

## TUCK KIT 4

- (2) 31" LED Tu Lights
- (1) 132" Power Cord
- (1) 18" Daisy Chain Cord
- (4) Magnetic Clips





**Air Master Systems Corp.**

6480 Norton Center Drive, Muskegon, MI 49441 • 231.798.1111 • 231.798.4000 fax • [airmastersystems.com](http://airmastersystems.com)